

IHOR GUARD

MODEL L75



INTEGRATED LIGHTNING PREDICTION AND WARNING SYSTEM

Owner's Handbook

INSTALLATION AND OPERATIONS MANUAL

REPLACE BATTERY ONLY WITH
ENERSYS ODYSSEY PC545
THORGUARD PART BAT104K

The protection provided by the equipment may be impaired if there is failure to use the equipment in a manner consistent and as specified by THORGUARD in this manual.

THOR GUARD Hardware License Agreement

License and Restrictions

THOR GUARD INC. (“THOR GUARD”) grants a limited nonexclusive license to use its models L25, L50, L75, L125, L150, the “Hardware” for the specific use of lightning prediction. User may not copy, modify the Hardware or disable any licensing or control features of the Hardware. No portion or functionality of the Hardware may be reproduced in any form, or by any means, without prior written permission from THOR GUARD. User is not permitted to duplicate, modify, distribute, publish, transmit or create derivative works of any Software associated with the Hardware or Hardware included for any public or commercial purposes. Except as specified above, nothing contained herein shall be construed as conferring by implication estoppel or otherwise any license or right under any patent, trademark or copyright of THOR GUARD, its affiliates or any third party licensor. User may not in any way sell, lease, rent, license, sublicense or otherwise distribute the Hardware. The Software may only access the functionality of THOR GUARD products in the Hardware. User shall not modify, translate, reverse engineer, decompile, duplicate, or disassemble the Software or Hardware, or any part thereof or otherwise attempt to derive source code or create derivative works or products therefrom, and shall not authorize any third party to do any of the foregoing unless THOR GUARD’s prior written consent is obtained. THOR GUARD may elect to provide to user updates and other support services for the licensed Hardware. All updates provided to User shall constitute licensed Hardware under this License, and such update shall be governed by the terms hereof. User is not permitted to use THOR GUARD to make any evaluation/comparison of any specific product, regardless of intention or for any specific length of time. Utilizing of any reproductive means, including photography, or any manual data recording of data and or any collection technique to secure displayed data is prohibited.

Intellectual Property

The Hardware used is owned and patented by THOR GUARD. User’s license confers no title or ownership in the Hardware and is not a sale of any right in the Hardware. The data stream, specifically the lightning data format used by THOR GUARD, is for the exclusive use in THOR GUARD products and there of its designated affiliates. THOR GUARD’s affiliates and or / third party suppliers may protect their rights directly in the event of any User violation of this agreement. The trademarks, tradenames, Product designation and logos, are the property of THOR GUARD. User is not permitted to use these marks without the written consent of THOR GUARD. THOR GUARD is a registered trademark of THOR GUARD, INC. User agrees not to remove, alter or destroy any patent, trademark or copyright markings or notices placed upon or contained within the Software.

Termination

User’s license will automatically terminate upon any attempted transfer of the Product. User must notify THOR GUARD of any intent to transfer, including in such notice the name and address of the intended transferee. The transferee must accept these License Terms as a condition to the transfer. Otherwise, THOR GUARD does not authorize the transfer and the User and transferee will be in violation of this Agreement should the transferee use the Product. THOR GUARD and its affiliates will not be liable and / or responsible for the necessary system hardware maintenance of equipment, specifically but not limited to (a) periodic Sensor cleaning, (b) written notification to THOR GUARD of any electrostatic altering devices installed after a THOR GUARD Installation, (c) the relocation of the Sensor by the User from the original installed location and (d) periodic testing of complete system. This license will automatically terminate upon User’s failure to comply with any of these License Terms. Upon termination, User and any unreported transferee must stop using the Product.

THOR GUARD Hardware License Agreement

Limited Warranty

THOR GUARD warrants to User that the Hardware will perform substantially in accordance with the published specifications for a period equal to 2 years from the original date of purchase when properly installed and used. Warranty does not apply to defects resulting from (a) improper or inadequate maintenance, (b) software, interfacing, parts or supplies not supplied by THOR GUARD and (c) unauthorized modification of the Software or the Products. If THOR GUARD receives notice of a covered defect(s) during the warranty period, THOR GUARD will replace Software that does not perform substantially in accordance with published specifications. THOR GUARD does not warrant that the operation of the Software and / or Products will be uninterrupted or error free. If THOR GUARD is unable, within a reasonable time, to repair or replace Hardware or Software to a condition warranted, User shall be entitled to a refund of the purchase price, subject to THOR GUARD.

EXCEPT AS SPECIFICALLY STATED ABOVE, THE SOFTWARE IS PROVIDED "AS IS" WITHOUT WARRANTY AND THOR GUARD DISCLAIMS ANY IMPLIED WARRANTY OF NONINFRINGEMENT, MERCHANTABILITY OR FITNESS FOR A PARTICULAR PURPOSE, THE REMEDIES IN THIS WARRANTY STATEMENT ARE USER'S SOLE AND EXCLUSIVE REMEDIES. EXCEPT AS INDICATED ABOVE, IN NO EVENT WILL THOR GUARD BE LIABLE FOR LOSS OF DATA OR FOR DIRECT, INDIRECT, SPECIAL, INCIDENTAL, CONSEQUENTIAL (INCLUDING LOSS OF PROFIT), CONTRACT, TORT, OR OTHER WISE, EVEN IF SUCH PARTY HAS BEEN ADVISED OF THE POSSIBILITY OF SUCH DAMAGES. IN NO EVENT WILL THOR GUARD OR ANY OF ITS AFFILIATES OR THIRD PARTY LICENSOR'S LIABILITY UNDER AGREEMENT, EXCEED THE COST OF THE PRODUCT.

THOR GUARD Lightning Data

The information recorded by the THOR GUARD lightning system is used exclusively for the purpose of providing lightning prediction at a single site location. The data, which is available by means of a serial port, 'RS232', or any communication device, both wired & wireless, is of a proprietary format exclusive to THOR GUARD. Use of this data for the purpose other than the connection with a THOR GUARD system, or THOR GUARD software is a violation of this Agreement.

General

This Agreement shall be deemed to have been made and executed in the State of Florida and both parties agree that any dispute arising hereunder related to this Agreement or the Product will be governed by the laws of the State of Florida exclusive of its conflicts of law principles and that the courts in the County of Broward, Fla. will have exclusive jurisdiction over all such disputes. FURTHER THE PARTIES HEREBY WAIVE TRIAL BY JURY IN CONNECTION WITH ANY ACTION OR SUIT ARISING UNDER THIS AGREEMENT OR OTHERWISE ARISING FROM THE RELATIONSHIP BETWEEN THE PARTIES. This Agreement shall be binding upon the parties authorized successors and assignees. Neither party's waiver of any breach or failure to enforce any of the provisions of this Agreement at any time shall in any way affect, limit or waive such party's right hereafter to enforce a compel strict compliance with every other provision. No modification of this Agreement shall be effective unless in writing signed by both parties.

Table of Contents

INTRODUCTION

License Agreement	iii
Limited Warranty	iv
Foreword	ix
Introduction	x
The THOR GUARD Approach	xi
System Technical Terms	xii

OPERATION

Front Panel	1
Lightning Display Data	2
System Data	3
Lightning Hazard Data	4
Current Time & Date	5
Typical Storm Data	6,7
L75 Top Panel	8
L75 Bottom Panel	9

SYSTEM SETUP

Menu, Change & Enter Keys	11
Set Current Date & Time	12
Set Default Alarm Time	13
Set Specific Alarm Time	14
Set Alarm Signals	15
Set Auto All Clear Mode	16
Set Red Alert Level	17
Set Alarm Auto/Man Mode	18
Set Alarm/Strobe Level	19

Table of Contents (Continued)

SYSTEM SETUP (Cont.)

Set External Relay Level	20,21
Set System Test Time	22
Set System Parameters	23
RF Output Test	24
VOTBD Battery Status	25
Review Storm Data	26
Factory Defaults	27

SYSTEM MAINTENANCE

Sensor Cleaning	29
Sensor Testing Procedure	30
Sensor Cable Splice	31
Reduced Sensor Signal Message	32,33

SENSOR & SYSTEM SERVICE

Testing Comm-Link Cable Output	33
Comm-Link Cable Test	34
Sound Test	35
Output Alarm/Relay Connections	36
External Relays Specifications	37

TECHNICAL SUPPORT

Questions & Answers	39-44
---------------------------	-------

INSTALLATION

Getting Started	45
Supplies Required	46
Choosing L75 Location/Power Requirements	47
Choosing Sensor Location	48
Mounting the Sensor	49

Table of Contents (Continued)

INSTALLATION (Cont.)

Running the Sensor Cable	50
Strobe Bracket & Strobe Light	51
Local Alarm/Strobe Cable	52
VOTBD Comm-Link Cable at L75	53
L75 Comm-Link Models B & R	54
Mounting VOTBD & Horn Assembly	55
Mounting VOTBD Base RF Antenna	56
Comm-Link Cable at VOTBD	57,58
Battery Connect, Power Up	59
VOTBD & VOTRC Solar Assembly	60
Preparing VOTRC & Horn Cluster	61
Mounting VOTRC, Horn Cluster, RF	62
VOTRC Electric Assembly	63

SYSTEM START UP & WARRANTY

Sensor Check	65
System Set-Up	66
Horn & Strobe Light	67
Warranty	68-70
System Diagram	71
System Specifications	Inside Back Cover

Foreword

THOR GUARD is a precision electrical instrument that requires some basic care to consistently provide the high standard of service designed into the equipment. Adhering to the following maintenance and operational guidelines is mandatory.

Basic Maintenance

It is imperative that the Sensor assembly is free from dirt, oil, pollen, cobwebs, and bird nests. A properly maintained THOR GUARD can provide adequate sensitivity insuring the full lightning prediction capabilities engineered into the system. Refer to System Maintenance, “Sensor Cleaning” for instructions.

You Don’t Always Have To Wait For THOR GUARD

THOR GUARD is designed to provide its user with reliable lightning prediction. If, however, you ever feel “uncomfortable” with incoming weather and THOR GUARD has yet to issue a RED ALERT...DON’T WAIT. Either sound the horns manually if you have them, or issue a warning to cease activities in your area. When it comes to safety, the only mistake you can make is through “IN - ACTION.”

Introduction

Thank you for choosing THOR GUARD as your Lightning Prediction & Warning System.

We are sure your Model L75 system will provide many years of trouble-free operation.

Depending upon your requirement, a specific model of the L75 was selected. All models will display lightning data, provide connection to a PC, and allow access to a controlled D.C. voltage output signal.

Model 75 will incorporate only the above features.

Model L75B will control THOR GUARD's VOT Alarm System providing control for a base horn and strobe light.

Model L75R allows for the addition of remote horns to be installed, utilizing a base VOT system.

Model L75I is for an application that necessitates having control using dry closure contacts. There are two sets of programmable contacts.

THOR GUARD is the only company in the world that provides lightning prediction technology. For more than 25 years, our method has proven to be extremely accurate.

You join many golf courses, parks, colleges, airlines and numerous industrial facilities that have selected THOR GUARD.

Enclosed with your system is a CD, which contains THOR PCX. This is a product of THOR GUARD and works exclusively with all THOR GUARD products. Using a PC, the user can log all lightning events and later "Replay" and view a specific storm.

Also available from THOR GUARD is THOR PCXNET that will allow multiple computers to view the current hazard using the customer's central server. The L75 connects to one computer on the network using a RS232 connection and copies the current lightning data to the server.

THOR GUARD APPROACH TO LIGHTNING WARNING

Lightning is the result of a massive exchange of electrostatic energy in the atmosphere. Shifts and changes of positively and negatively charged “ions” in the atmosphere and in the ground could create an energy flow that may result in a lightning strike once a path is available. A lightning “prediction” system senses and evaluates these shifts and changes in the electrostatic field that precede the occurrence of an actual lightning strike.

The THOR GUARD system was designed to evaluate the electrostatic field and compare the energy migration of the positive and negative “ions” to a computer model developed during thousands of hours of recorded storm data. The THOR GUARD system is comprised of two essential elements. The first, the “Hyperstatic Sensor” assembly, constantly monitors the electrostatic field from its typical location on the top of a structure. The primary coverage area for this system is calculated using a maximum, but adjustable radius of 2.5 miles (5 miles in diameter). The total area being monitored, however, is a range that is adjustable to a maximum radius of approximately 15 miles.

The sensor communicates the data over a special cable to the second element, the THOR GUARD computer console. The computer evaluates the information 500 times per second within its integrated circuitry and produces two important potential lightning threat levels. The first is called the Lightning Hazard Level, or “**LHL**.” The “**LHL**” is displayed on a scale of zero (0) to nine (9) and represents the threat of lightning potential in the total area being monitored. The “**LHL**” responds to instantaneous positive and negative energy shifts and relative intensity. (Note: All THOR GUARD systems are accurate to 1mv at 15 miles).

The second important lightning threat level is called the Dynamic Index, or “**DI**.” The “**DI**” represents the lightning threat in the immediate (2.5 mile or less radius) area being monitored. This value is ascertained by relating the overall “**LHL**” level to local shifts in positive and negative energy. As above, the “**DI**” threat level is displayed numerically, on a scale from 0% to 99%.

THOR GUARD System Technical Terms

Polarity – THOR GUARD distinguishes between positive and negative polarity because during most storm conditions, a negative electrostatic field of the same intensity as a positive field poses a much higher lightning hazard threat level. The intensity and shifts in polarity may be observed on the “Energy Level” LED bar. Negative polarity is displayed in red, and positive polarity is displayed in yellow.

LHL (Lightning Hazard Level) – This is the probability of a lightning strike occurring within the defined area or range (up to 15 miles) being monitored by the facility. The LHL will be the first and last indication that energy is present in the total area monitored.

DI (Dynamic Index) – The measurement of the electrical activity in the immediate area and the probability, from 0-99%, that if lightning strikes, it will strike nearby (2.5 mile radius). The DI determines the warning level based on energy migration in your immediate area. A “DI” of three (3.0) will trigger a “Red Alert” condition which should provide a warning margin of eight (8) to twenty (20) minutes before the arrival of local lightning activity.

BOB (Bolt Out of the Blue) – The condition in which very powerful lightning discharges may occur even with no visible clouds in the immediate area. A BOB may emanate from a weather front up to 50 miles away.

AD (Activity Detector) – The “Activity Detector” is an estimate of how much time will elapse before normal activities may resume. This number will be reset every time a major excursion of energy (i.e., lightning strike) is recorded. The Activity Detector indicates the time in minutes before an “All Clear” will sound. During a storm, the AD will be reset depending upon the discharge and the energy present. The Activity Detector running time has a maximum of 10 minutes after which the system will return to the “All Clear” status.

FCC (Field Collapse Count) – The FCC represents individual electrical energy discharges within the total coverage area and is a good indication of the storm intensity.

Range – This is the total area being monitored by the THOR GUARD sensor. The Range setting may be adjusted to give a longer or shorter time interval between a “Red Alert” warning and the arrival of local lightning.

Operation

Front Panel



Energy Level.. The amount of energy currently in the atmosphere is indicated. As a storm approaches, the display will change and track the instantaneous energy.

All Clear..... Permits the user to manually sound the signal to provide the signal of 3 blasts , 5 seconds apart.

Red Alert..... Permits the user to manually alert personnel to an approaching hazard by sounding the horns.

Change/Test... Allows momentary display of the date & time, or to manually test the sensor.

Alarm Mode.. Switches between an attended system, where the user controls the horns, to an automatic system control.

Mute / Enter.. Eliminates the audio alarm during a storm, or accepts changes when in the menu mode.

To check the internal audio, press mute when at an All Clear.

Operation

Lightning Display Data



LHL...Lightning Hazard Level, on a scale from 0 to 9, indicates the threat of a lightning potential in the ***total area monitored***. A value of 9 indicates a strike most likely will occur in the area. During clear or cloudy days, a value of 1, 2 or 4 may occur.

DI.... Dynamic Index may have a value from 0.0 to 9.9. The value represents the immediate lightning threat (2.5 mile radius) in the area monitored. As shifts in energy occur, the DI will increase or decrease. At a value of 3.0, the RED ALERT hazard is activated and will be maintained until an All Clear level is present.

If the DI reaches 5.0 and begins descending, the storm may be moving out of the area. The hazard is still present and safety procedures should still be in place.

AD....This is a lightning hazard “minute” timer to inform you when the system will determine the area is safe. The value starts at 10 and decreases unless storm activity reoccurs. It is common for the AD to return to 10 during a storm. Once the AD reaches 0, the All Clear condition is present.

FCC...As lightning strikes and energy shifts move towards the monitored area, this number will increase, slowing as the area becomes safer. A quick changing FCC indicates numerous lightning strikes in the area. This value is maintained until the next storm triggers the AD.

Operation

System Data



All Clear (Auto)Test()
LHLO DIO.0 AD . . FCC 000

Auto / Man.....The user can select whether the system will sound the horns automatically, or unattended, or require manual activation. By pressing the “**ALARM MODE**” key, the system will change to the opposite. At the beginning of the next day, the programmed default will return. See Page 18.

When in the Auto Mode, after a RED ALERT occurs , the All Clear signal will sound if the user has enabled the L75 AUTO ALL CLEAR mode. See Page 16.

TestThe L75 will check the sensor every 24 hours. After the test, the results are displayed with a single letter except on power turn on.

- Test () Blank..no test / power was off.
- Test (P) Pass sensor test in last 24 hours.
- Test (F) Failed sensor test.
- Test (H) Requires L75 replacement.

Operation

L75 Lightning Hazard Data



All lightning data is consistently being displayed during operation.

Hazard Levels

The four separate hazard levels are All Clear, Caution, Warning and Red Alert, each displayed based on the current energy activity.

All Clear . There is no significant energy. This will usually indicate that there is a safe environment.

Note: If the Test has a letter (F) displayed, you may want to initiate a manual sensor test on the system.

Caution ... Normal atmosphere energy shifts are occurring and depending on the situation, may increase to a Warning.

Warning... A significant amount of energy has moved into the area being monitored. Depending on your application, monitor the L75 for increased DI and FCC counts. If your system is equipped with horns, determine if you should activate the RED ALERT horns. Otherwise, allow the system to continue monitoring the storm. Depending on the storm, it may pass by without achieving to a RED ALERT level.

Red Alert .. The conditions for a local strike are prevalent. Activities should cease and seek immediate cover. Increasing DI values and/or FCC counts increase the possibility of a local strike and increased risk.

Operation

L75 Current Time & Date



8/06/03 10:30 am RAA1225
LHLO D10.0 AD . . FCC 000

By pressing the “CHANGE” key, the current time and date will be displayed for five seconds. The display will maintain and update all Lightning Hazard Data on the bottom line.

The upper right corner of the display will provide the L75 model type, installed software revision, system range, and specific storm parameters. These values will allow THOR GUARD to easily determine the current lightning prediction parameters that are set in your system.

As an example, RAA1225 indicates a system with remote horns (R), the software is AA, the range is 12, and the storm parameters are 25.

After 2 seconds, the lower display will indicate “Press Test.” If your desire is to test the sensor, press “CHANGE” now.

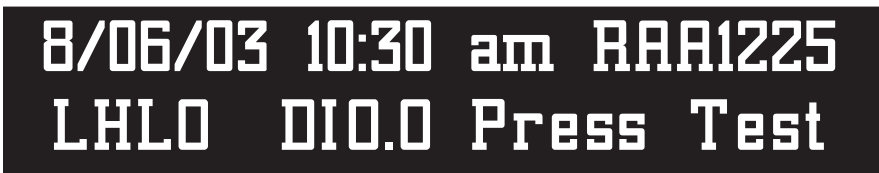

8/06/03 10:30 am RAA1225
LHLO D10.0 Press Test

The system will begin a sensor test and update the results on the main display.

Operation

Typical Storm Data

```
All Clear (Man) Test (P)
LHLO DI0.0 AD .. FCC 000
```

Here is a typical day with no activity. Notice that the sensor passed its test. Also the operator has the L75 in the manual alarm mode.

```
Caution (Man) Test (P)
LHL4 DI0.0 AD .. FCC 000
```

The system shows a change in the activity. The energy is still less than what is required to trigger the AD.

```
Warning (Man) Mute( )
LHL6 DI2.6 AD 9 FCC 003
```

A series of strikes have entered the monitored area. Depending on storm characteristics, the DI and FCC might increase. The audio alarm within the L75 is enabled.

```
Red Alert (Rf Send Cmd)
LHL9 DI3.0 AD10 FCC 004
```

The storm has met the hazard level of the L75 to activate the horns. The user pressed the **RED ALERT** key since it was in manual mode.

Operation

Typical Storm Data (Cont.)

**Red Alert (Alarm Sent)*
LHL9 DI3.1 AD 9 FCC 005**

The storm intensifies. Notice the DI & FCC increases. The user is told that the alarm was sent and the “*” indicates the Local Strobe or Remote Strobe are active.

**Red Alert (Alarm Sent)*
LHL7 DI2.3 AD 5 FCC 007**

The storm is leaving the area and the DI is decreasing. The user is advised that the local audio alarm is on. Also, the “*” indicates the strobes lights, both base and remote, if installed, are active.

The LHL level has decreased indicating a reduction in electrical activity. There still remains a high threat for a lightning discharge in the total area monitored.

The system indicates the alarm has been sent, either manually or automatically.

Operation

Top Panel

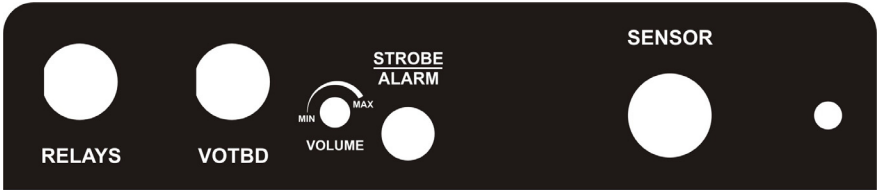

Model 75I allows connection to internal dry closure relays. Each set of contacts can be programmed to allow two separate hazard levels if required.

Models 75B and 75R drive the THOR GUARD VOT SYSTEM. Connection to the base horns (VOTBD) is made at the 5 pin VOTBD. This is where the “pigtail” connector attaches.

Internal volume level is set using a small flat blade screwdriver and turning the recessed adjustment, left to decrease, right to increase.

Access to the local alarm is with an RCA type connector. When the hazard local alarm level matches or exceeds the user setting, a +12 vdc @ 500ma. voltage signal is present.

The THOR GUARD sensor, located on the roof, connects to the sensor input. Examine the sensor connector, and insert with the recessed notch in the metal facing up. There is only one direction the connector will seat properly.

Operation

Bottom Panel

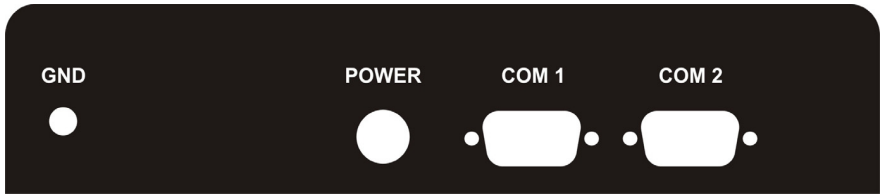

The GND (ground) screw is to be used in the event your AC power does not have a 3- prong pattern. Attach an insulated #22awg. wire, enclosed with your unit, from the center screw of your AC outlet to this point. Make sure the connections are secure.

The wall-mount transformer attaches to the AC power input or UPS if used. Press plug connection to L75 firmly. Loosen the ground screw and route the power cable through the strain relief that is attached. **Leave a service loop to remove power if needed.**

Separate RS232 com ports are provided to allow access to the L75 lightning data. When you install THOR PC, you may connect to either Com 1 or Com 2. Data is sent at 9600 baud, updating once per second.

Operation

(Blank page)

System Setup

Menu, Change and Enter

There are several models of the L75. Some specific menus for each model that do not apply will be omitted from the display.

Three keys are used to alter the system parameters. All changes will be stored regardless of the power status of the system until otherwise modified by the user.

If you remain in a menu for five minutes without any key entry, the system will automatically return to the normal operation mode.

MENU: This key permits you to access the **SETUP MENU** for the purpose of customizing your system operation. Continue pressing **MENU** until the **EXIT** option is given. Then press **ENTER**.

CHANGE: This key allows you access or to make the required change in a parameter, depending on the options available.

For individual parameters, the current value that you will be changing will blink as an aid.

ENTER: This key will either advance you through different fields in a specific menu, or it will store the changes and advance to the next menu item.

If you mistakenly press **MENU** before **ENTER**, all current parameters will remain the same. It will be necessary to continue pressing **MENU** until the required menu choice reappears and re-enter your changes.

System Setup

Set Current Date & Time



CURRENT DATE & TIME
4/6/03 SUN 4:23 pm

The display will show the current date, day and time. The parameter you will be changing will “blink.”

If you want to have the parameter self advance, hold down the **CHANGE** key. Otherwise manually press the **CHANGE** key and release at the required setting.

If Month is correct, press **ENTER**, or press **CHANGE** until correct month is displayed.

If Date is correct, press **ENTER**, or press **CHANGE** until correct date is displayed.

If Year is correct, press **ENTER**, or press **CHANGE** until correct year is displayed.

If Day of week is correct, press **ENTER**, or press **CHANGE** until correct day of the week is displayed.

If Hour is correct, press **ENTER**, or press **CHANGE** until correct hour is displayed. Ensure you have the correct AM or PM selection.

If the Minute is correct, press **ENTER**. You will advance to the next menu item. Otherwise, press **CHANGE** until correct minute is displayed, then press **ENTER**.

System Setup

Set L75 Default Alarm Time



The system default 7:00 am to 8:00 pm.

L75 Available User Default Settings

On 7:00 am	Off 8:00 pm
On 6:00 am	Off 8:00 pm
On 7:00 am	Off 5:00 pm
On 6:00 am	Off 9:00 pm
On 5:00 am	Off 11:00 pm
Continuous Operation	
Default Disabled	

All the default options are set for the same time, Monday - Sunday.

There are numerous time settings that may meet your requirements. Select a system time setting, or if you find that a custom setting is required, select “Default Disabled” and then press **ENTER**.

If you require the system to remain active all the time to allow control of the alarms, whether manually or automatically, select “Continuous Operation”.

Press **ENTER** to make a change or advance by pressing **MENU**.

If the correct setting is displayed, press **ENTER**.

System Setup

Set Specific Alarm Time



You must have previously selected “Default Disable” to allow access to individual day settings.

Press **ENTER** to allow access to make a change.

The alarm “active time” can be set for each day. Each day is restricted to having one active time. The specific value you will be changing will blink.

Starting with Sunday, press **CHANGE** to advance the hours “time on.” Press **ENTER** when complete.

Press **CHANGE** to advance the “minutes on.” Press **ENTER** when complete.

Press **CHANGE** to advance the “hours on.” Press **ENTER** when complete.

Press **CHANGE** to advance the “minutes off.” Press **ENTER** when complete.

The alarm active time for this day is now stored in the system. Continue with each day of the week until all times have been set.

Pressing **MENU** will be necessary to exit this setup. To ensure correct setting, you may wish to continue pressing **MENU** until this menu item returns. Then press **ENTER** continuously to verify you have correctly programmed the selected alarm active times.

System Setup

Set Alarm Signals

RED ALERT 1x 15Sec Blast
ALL CLEAR 3x 5Sec Blast

The user can select a specific alarm horn pattern or use the default setting.

Red Alert (1X @ 15 sec.); All Clear (3X @ 5 sec.) “**DEFAULT**”

Red Alert (2X @ 15 sec.); All Clear (3X @ 5 sec.)

Red Alert (1X @ 10 sec.); All Clear (3X @ 5 sec.)

Press **ENTER** to view current setting or **MENU** to advance to the next setup.

Otherwise, press the **CHANGE** key until the pattern you required appears.

Press the **ENTER** key, the new pattern is loaded in the system.

If you press **MENU** before **ENTER**, the currently stored value will not be changed.

NOTE: No change can be made to the All Clear alarm pattern.

System Setup

Set Auto All Clear Mode



SET AUTO ALL CLEAR MODE
All Clear Alert Auto

Once a storm leaves the area, and after the RED ALERT horns have sounded and the L75 determines that a safe condition now exists, the All Clear pattern will be sounded automatically by the L75 system or will require the user to activate manually.

The system default is Auto.

Press **MENU** to advance to the next setup.

Press **ENTER** to view the current parameter.

Press **CHANGE** to select your choice, either Auto or Manual, then press **ENTER**.

System Setup

Set Red Alert Level

L75 Red Alert Level
Current Level 3.0 0.0

RED ALERT is when the L75 has determined the chance of a strike within the monitored area is present.

Depending on the application and environment, the user may want to increase their alert time. This is possible by adjusting the Red Alert Level.

Use caution because if the value is set low, some storms may have not yet fully developed and may cause the alarms to sound inadvertently.

Contact THOR GUARD or your area representative for assistance.

The system default is 3.0.

Press **ENTER** to view current setting or **MENU** to advance to the next setup.

Press **CHANGE** to alter the red alert level.

Values of 2.5 (minimum) to 3.0 (maximum) can be selected.

Press **ENTER** to store the value.

System Setup

Alarm Auto / Man Mode



The image shows a black rectangular area representing an LCD display. The text is displayed in a white, pixelated, monospace font. The top line reads "SET ALARM AUTO/MAN MODE" and the bottom line reads "Alarm Auto Mode".

When the L75 reaches the RED ALERT level, it is necessary to alert personnel and sound the alarms.

The system default is Auto.

If this setting is Auto, the RED ALERT horn pattern will be triggered. If Manual is selected, the user is responsible for sounding the horns by pressing the **RED ALERT** key.

During the day, you can alter this mode by pressing the **ALARM MODE** key. The start of a new day will return the alarm mode in the system to the selection set by the user.

Press **ENTER** to view current setting or **MENU** to advance to the next setup.

Press **CHANGE** to select between Auto or Manual.

Press **ENTER** to store the selection.

System Setup

Set L75 Alarm / Strobe Level

SET L75 ALARM/STROBE LEV
Active on Red Alert

The user can control a local strobe light or device that requires +12v DC @ 500ma.

Located on the topside under the plastic cover, is an RCA type female receptacle. The center will have +12 applied continuously during the level the user has selected as his minimum level hazard. The case of the RCA receptacle is ground.

Decide at what hazard level, Caution, Warning or Red Alert you want the signal to be active. It is possible to disable the output.

The system default is Disabled, Constant and 24 Hours.

Constant Relay Closure

Decide if you want to have a constant closure output or a “timed” output for a period between 5 – 15 seconds.

Press **ENTER** to view current setting or **MENU** to advance to the next setup.

Press **CHANGE** to alter the hazard level when the output will be active or Press **ENTER**.

Uses Alarm Time Settings

You can have the output be active 24 hours or it can follow the programmed alarm time settings.

Press **ENTER** to accept the output mode or Press **CHANGE** to increase the time or select “Constant Relay.”

Press **ENTER** to accept the time mode or press **CHANGE** to use the system programmed alarm time settings.

System Setup

Set External Relay Level

Set External A.B. Relay

If equipped, your L75 will trigger two internal relays and provide contact closure for the user. By setting the profile for each relay, you can control the time and method of contact that each will use. Access to the Normally Open, Normally Closed and Common contacts are provided using a removable 6-pin male connector with a 2-ft. cable.

Each relay is independent and can be set to one of two modes; to be active for a specific time in seconds, 5–15, or the contact will stay in an energized mode until the current hazard returns below the hazard which you have selected.

Each relay will remain energized once a Red Alert occurs. When an All Clear returns, the relay will de-energize.

The time the relay will be active can be set to be 24 hours, function all day, or to follow the program of the alarm time parameters of the system.

The alert levels can be Caution, Warning or Red Alert.

The system default for both relays is set at Red Alert, and Constant and energized.

Press **ENTER** to view relay settings or **MENU** to advance to the next setup.

Press **CHANGE** to alter relay “A” hazard level. Press **ENTER** when done.

System Setup

Set External Relay Level (Cont.)

**Ext Relay A Hazard Level
Active on Red Alert**

Press **ENTER** to view relay “A” output mode.

Press **ENTER** to accept the output mode or press **CHANGE** to increase the relay active time.

**Ext Relay A Output Mode
Relay Active 5 Seconds**

Press **CHANGE** to increase the time to a maximum of 15 seconds. After 15 seconds, you will have the “Constant” option again.

Press **ENTER** when your setting is complete.

**Ext Relay B Hazard Level
Active on Red Alert**

Press **ENTER** to accept Relay “B” output mode or press **CHANGE**.

**Ext Relay B Output Mode
Relay Active 5 Seconds**

Press **CHANGE** to increase the time to a maximum of 15 seconds. After 15 seconds, you will have the “Constant” option again.

Press **ENTER** when your setting is complete.

System Setup

Set System Test Time



Current Sensor Test Time
10:00 am

The L75 system will do a test on the sensor every 24 hours at a pre-selected time. The result of this test is placed on the main operation display while displaying lightning hazard data.

The time selected should make allowance for “Dew & Moisture” to have burned off. If the system fails, internal re-testing will occur attempting to get a “Test Passed” condition.

The system default is 10:00 am.

Press **ENTER** to view current setting or **MENU** to advance to the next setup.

Press **CHANGE** to alter the hours. Ensure the correct am or pm setting. Press **ENTER** when complete.

Press **CHANGE** to alter the minutes. Press **ENTER** when complete.

System Setup

Set System Parameters

Range (12)	Front (2)	Back (5)
-----------------------------	----------------------------	---------------------------

Your system has been pre-programmed at the factory for the best settings within your area and type of use. Slight adjustments may be necessary after use.

The sensitivity of the system and storm-related settings are controlled here. After a couple of storms, the user may decide that a change to the RED ALERT notification time or when the All CLEAR is sounded is required. This could mean a change to the range setting is necessary.

Contact THOR GUARD or your area Representative and the suggested settings will be given to you. **DO NOT UNDERTAKE THIS WITHOUT FIRST CONSULTING WITH THOR GUARD.**

The system default is Range(12) Front(2) Back(5).

Press **ENTER** to view current setting or **MENU** to advance to the next setup.

Press **CHANGE** to alter the Range value. The value in the () is the current system setting.

Press **ENTER** to move to the Front setting and using **CHANGE** , change value as recommended by THOR GUARD. Otherwise press **ENTER**.

Press **CHANGE** to alter Back setting as recommended by THOR GUARD. Otherwise, press **ENTER** to make changes and advance to the next setup.

System Setup

Rf Output Test

Change Time, Press Enter
Rf Test Time Min = 30

The Rf Output Test has been designed to allow the signal from the transmitter to be transmitted and received by the various remote alarm locations automatically. When activated, this test continuously sends the Rf signal (every 30 seconds, per display) for a period of 30 minutes, unless manually deactivated through this Menu.

To initialize the Rf Test, push the **ENTER** Key and the “ACTIVE” notice should start blinking, indicating that the test is running. A counter of how many test signals have been sent will be displayed on the top line of this display.

Rf Test 001 Next Test 30
Press Menu To Exit

If you don't want to wait 30 seconds between tests, push the **ENTER** key and the test will be repeated.

To exit or stop test, press the **MENU** key.

System Setup

VOTBD Battery Status

VOT BATTERY STATUS
No Service Required

The Voice of THOR Base Control (gray enclosure) utilizes a 12-volt lead acid sealed rechargeable battery to provide power for the base horns. This is a high-quality battery and should be replaced with one of the same type.

Each time the horns are activated, this parameter will be updated.

Press **ENTER** to view current battery status or **MENU** to advance to the next setup.

VOT BATTERY STATUS
Service Required

When the display indicates “Service Required,” check the battery and battery charging voltage. A system restarted after a winter shut-down may require 48 hours to recharge the battery. Service as needed.

Measure battery for +12 volts when horn test button is being pressed. Replace battery if it is +10.5 volts or below when horns are active, or allow sufficient time for battery to recharge.

Resetting of the Service Required message will occur when you pressed **ENTER**.

System Setup

Review Storm Data

```
04/04/03 A 4:40p Buf 11
LHL8 DI2.4 AD10 Warning
```

The L75 maintains an event storm buffer. This data will show the user if there is a L75 power problem, and provide the date and time that alarms were active. The alarm mode and all lightning data can be observed in sequence as the storm occurred.

The top line displays the date & time for each hazard. The letter between the date & time indicates a power issue, (S) for a system reset or (P) for a AC power reset. The alarm mode is Auto or Manual (A or M).

The lower line displays the LHL, DI, AD and hazard level.

Once the DI reaches 5.0, data is not stored to the buffer.

The buffer is limited to 60 events. Data is stored first in, last out.

```
08/06/03 A 10:00a Buf 06
LHLO DI0.0 AD00 Test (P)
```

The time and results, “F” or “P” of the sensor test are stored.

To maintain a long-term record of events, **THOR GUARD'S THOR PCX** software (requires a PC) should be utilized with the L75.

Press **ENTER** to view first buffer or **MENU** to advance to the next setup.

Press **ENTER** to advance the storm buffer.

System Setup

L75 Factory Defaults

L75

Default Alarm Time 7:00 am - 8:00 pm
Auto All Clear Mode Auto
Red Alert Level 3.0 (Highly Recommended)
Alarm Auto/Man Mode . Auto
System Test Time 10:00 am
System Parameters (12) (2) (5)
Alarm / Strobe Disabled, Continuous, 24 Hours
External Relay "A" Red Alert, Continuous, 24 Hours
External Relay "B" Red Alert, Continuous, 24 Hours

User's Settings

L75

Default Alarm Time _____
Auto All Clear Mode _____
Red Alert Level _____
Alarm Auto/Man Mode .. _____
System Test Time _____
System Parameters _____
Alarm / Strobe _____
External Relay "A" _____
External Relay "B" _____

System Setup

(Blank page)

System Maintenance

Sensor Cleaning

THOR GUARD requires that the Sensor be cleaned and checked at regular intervals to maintain optimal performance. The local environment where the Sensor is located will dictate the frequency of cleaning. Particularly during the active storm period, *monthly* cleaning may be necessary to ensure accurate lighting prediction and prudent checking of the Sensor to be free from dirt, oil, pollen, cobwebs, and bird nests should be performed.

All the PVC area, especially those indicated, should be cleaned with new damp paper towels. Old rags or other cleaning materials may contain contaminants that will attach to the PVC, leaving a residue. Allow PVC to dry or use dry paper towels before retesting.

Both sides of the hyperstatic plate should be cleaned. Remove any cobwebs that maybe present between the plate and domes.

The bowls may discolor with time. This is a normal occurrence and will not affect the operation of the system.

System performance will be compromised if cleaning of the sensor is ignored.

Ensure to set the alarm mode to (MAN) while you test the sensor and then return to the previous alarm-operating mode.

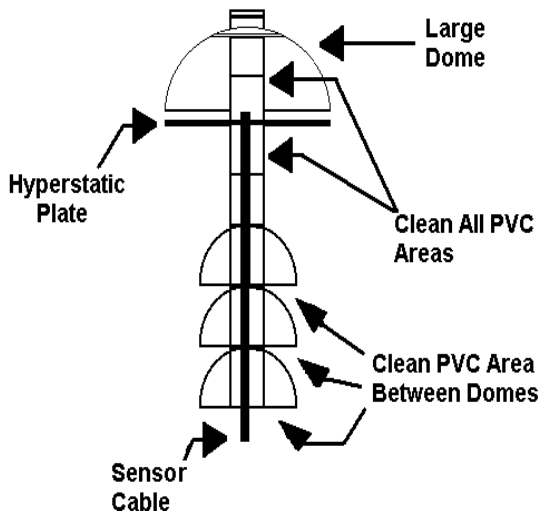

System Maintenance

Sensor Testing Procedure

Your THOR GUARD has been programmed to run a sensor test every 24 hours. If the system passes the test, the display will indicate Test (P). The test may also be run manually (unless there is storm activity) by depressing the **TEST** key on the front panel. Wait until “Press Test” is displayed and then press the **TEST** key.

Ensure to set the alarm mode to (MAN) while you test the sensor and then return to the previous alarm-operating mode.

If the sensor test fails, the letter (F) will be displayed, however, the system will continue to operate with reduced sensitivity as long as the sensor cable is attached. Additional tests will automatically be performed over the next 24 hours.

If it is raining or snowing, the sensor may not pass the test until the conditions change.

Should the unit continue failing the test in a clear day.....

THE SYSTEM MAY NOT BE OPERATIONAL

Check that the sensor connection on the back of the L75 is secure.

Remove L75 power, detach sensor cable and insert gray test plug which is attached to the top side of the L75.

Follow the procedure for cleaning the sensor (Page 29).

Perform sensor test, and if test passes, then remove power, re-attach sensor cable. Press **TEST** and run sensor test. If test fails, contact your area representative or THOR GUARD.

System Maintenance

Sensor Cable Splice

- (1) Cut a piece of sensor cable approx. 8" long and set it aside.
- (2) Strip 3" of the black outer cover of the triaxial cable.
- (3) Push down on braided wire to loosen from cable; then carefully separate and twist into a single, straight bushy piece.
- (4) Strip clear sheath leaving approx. $\frac{3}{4}$ " from the base of the braid above. Remove the aluminum foil cover. Repeat setup 3, except braid wires and position on opposite side.
- (5) Strip white center cable $\frac{3}{4}$ " from inner braid leaving 1" of solid copper wire exposed. Connect two center wires, ensuring both set of braids will overlap. Adjust lengths of wires if necessary.
- (6) Hook center conductors together and solder using rosin core 60/40 solder. Ensure solid connection. Tape over connection.
- (7) Make solder connection between each set of braids, leaving a smooth finish. Tape to insure good insulation and avoid contact with 2nd set of braided wires. Check for any pieces of stranded wires that may have shorted together.
- (8) Repeat procedure 7 with outer braid.
- (9) Take the 8" piece of cable and tape to outside of the entire splice.
- (10) Cover splice generously with tape to protect from water.

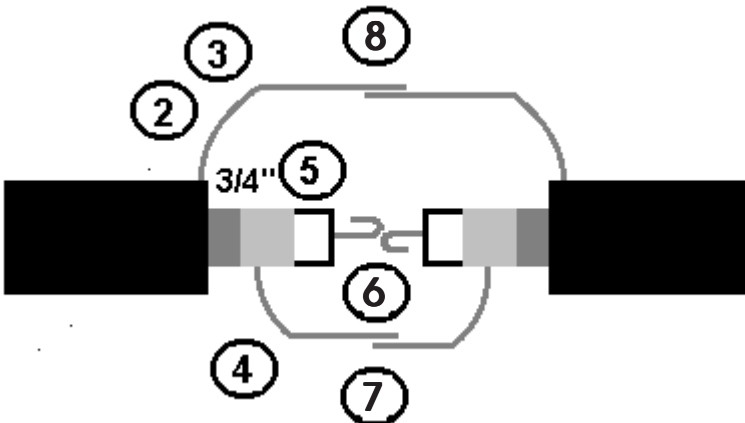

System Maintenance

Reduced Sensor Signal Message

**All Clear (Auto) Test (F)
Reduced Sensor Signal**

Once during a 24-hr. period, the system will check the sensor at the time you have selected. In the event a failure occurs, represented by a letter (F) on the display, the system will attempt to do a “Re-Test” at a pre-determined time interval. When the system determines that the sensor will not pass a test, usually after two days of consecutive failures, the test will indicate a warning message with the letter (S). ***Immediate attention must be given to determine the cause, as system performance will be compromised.***

The cause for this failure can be any of the following:

- (1) The sensor is extremely dirty and requires cleaning.
- (2) There has been continued rain or snow and the sensor has too much moisture on the PVC located between the plate and the top (big) dome.
- (3) A chemical has been applied to the sensor plate or PVC area when routine cleaning was performed.
- (4) The sensor cable has been removed from the L75.
- (5) If a splice was used during the installation , the sensor cable center conductor (inside foam) may have become broken.
- (6) The sensor cable has become pinched or crushed. The outer black jacket has allowed water to corrode the shield.
- (7) Test the L75 using the “Test Plug” to determine whether the L75 or the cable/sensor is at fault.

Sensor & System Service

Reduced Sensor Signal Message (Cont.)

L75R Diagnostic AA 1225
System Test Press Alarm

During the time that you will be cleaning the sensor, you do not want the horns to sound. You can either change the alarm mode to (MAN) manual or stay in this menu. If you elect to change the alarm mode you will have to wait for the system to time out, or remove power.

An option is given to enter the System Test mode by pressing the **Alarm Mode** key. Otherwise, press the **MENU** key when done.

Testing L75 Comm-Link Output

L75 VOTBD Output Test
Enter = Yes, Menu = No

If there is a problem between the L75 and the VOTBD, you can determine whether the L75 comm-link output is operational. Remove the comm-link cable and press **ENTER** to do the test. The status of the comm-link output will be displayed.

Remove Vot Cable to L75
Vot Passed Press Enter

Failure to remove cable will cause incorrect result of test.

Sensor & System Service

Comm-Link Cable Test

Comm-Link Cable Test
Enter = Yes, Menu = No

The VOTBD has a multi-conductor cable attached to the L75. To check the cable with the transmitter attached, press **ENTER**. A short delay before testing may occur. The results of the test will be displayed. A “Comm-Link Failed” indicates the transmitter failed to respond to the L75 test. If you have already performed the L75 comm-link output test, check and make sure the transmitter phone plug (located in VOTBD) is correctly seated. Check the voltage of the battery located in the VOTBD, 11.0 vdc minimum, while sounding horns manually. Replacement of transmitter may be required.

L75 Strobe / Relay Test
Test = Off/On, Enter = Next

The strobe/alarm output can be manually checked using the **TEST** key. The output will change from +12vdc to 0 volts. When done press the **ENTER** key to continue or press **MENU** key to exit system diagnostics.

Ext Relay A Output Off
Test = Off/On, Enter = Next

The “A” external relay output can be checked. Press the **TEST** key and the relay will energize. The display will indicate the status. Press the **TEST** key and the relay will de-energize.

Press **ENTER** and now the “B” relay can be checked in a similar manner.

Sensor & System Service

Sound Test

**L75 Sound Off
Test= Off/On, Enter =Next**

The internal speaker can be checked. Press the **TEST** key to change from no sound, solid tone, or warble. This will allow for the correct volume level to be set.

Note: When the L75 is at an All Clear, the Mute key can be pressed to check the audio level.

**Reset System To Default ?
Change = Yes, Menu = No**

Depending on the situation, it may become necessary to have the L75 be reprogrammed with the “Factory Default Parameters”.

Note: All storm buffer data, user specific alarm times and relay parameters will be altered and are not recoverable.

Press **CHANGE**, and you have 20 seconds to change your mind.

Press **MENU** to exit the L75 diagnostics.

Sensor & System Service

Output Alarm Connections

VOTBD Cable

If your system uses a THOR GUARD horn alarm system, you were provided a 6-conductor pigtail cable. The function of each wire is as follows:

<u>Pin</u>	<u>Color</u>	<u>Function</u>
1	Blue	Data to Transmitter (-7v or +7v)
2	White	Data from Transmitter (-7v or +7v)
3	Brown	Separate Relay Output
4	Black	Ground
	Green	Ground
5	Red	Battery Charging Voltage (more than 13.5v)

The green wire is attached in the connector to the black wire (ground) and is used to connect to the TG27 comm-link cable.

Connect the shield in this cable at the L75 to an AC ground.

Strobe /Alarm

All L75 systems have a local alarm. A RCA type connection is used to access the signal. The center conductor is +12vdc and the outer (shield) is ground. This will provide power to any device, light or relay or buzzer, which draws 500 ma. (.5A) or less.

External Relays “A” & “B”

As an option, the L75 will allow access to user programmed hazard relays. A removable 6-conductor cable is provided.

<u>Pin</u>	<u>Color</u>	<u>Function</u>
1	Brown	Relay “A” Normally Closed
2	Black	Relay “B” Normally Closed
3	Blue	Relay ”B” Common
4	Red	Relay “B” Normally Open
5	White	Relay “A” Normally Open
6	Green	Relay “A” Common

Sensor & System Service

External Relays Specifications

The internal relays within the L75I are dry closure, meaning no voltage will be provided and the user has access to the Normal Open, Normal Closed and Common contacts. The user is required to provide if and when necessary, protection to limit the voltage or current allowed to be switched by the contacts.

The relays should be used to switch a maximum of 120v AC @ 1.0A. or 30 VDC @ 4A. Inductive loads, such as motors, should be connected to a separate relay, using the L75 to provide the closure for the relay coil circuit.

(Blank page)

Technical Support

Questions & Answers

Question

My system has been working fine. What would cause my THOR GUARD system to become less sensitive?

Answer:

1. Dirty sensor.
2. New equipment installed on roof affecting sensor reception.
3. Adjacent tree has grown taller and is absorbing energy.
4. New building structure restricting airflow.
5. Grounding strap has been attached to the sensor.
6. Recent painting in the area has coated sensor.
7. Check the ground for the L75.

Question

The system goes off on a clear day. What would cause my THOR GUARD to become overly sensitive?

Answer:

1. The sensor was cleaned with a cloth rag impregnated with a fluid other than water. (Sensor replacement maybe required)
2. One or more spider webs are grounding the plate and the bowls.
3. A compressor or electric motor has been located near the sensor and may be sharing the same AC Circuit.
4. Someone has installed an energized cable along the same path (or tied) as the sensor cable.
5. Birds have nested in the sensor assembly.

Question

I have been passing my sensor test repeatedly, however, now my system is failing the sensor test. What should I do?

Answer:

1. Check to see sensor plug is attached to L75 firmly.
2. Dirty sensor, clean PVC area and sensor plate, check for spiders.
3. If there is consistent rain, PVC area too wet to allow to pass. System will still monitor for storms.
4. Try using sensor test plug, and see if sensor test passes.
5. Contact a representative or THOR GUARD if problem persists.

Technical Support

Questions & Answers

Question

Just installed my system and after a few storms, I feel I am given too much time before the storm arrives. What can be done?

Answer:

1. The range of your system needs to be adjusted. In the System Parameter Section, reduce the range by one value. As an example, if your range was at 12, change it to 10.

Question

New installation, I have storms that are too close before I am notified. What do I do?

Answer:

1. First, make sure the sensor has been mounted as required and sufficient airflow exists at the sensor location.
2. In some geographic areas, storms come predominantly from one direction. See if sensor placement can be relocated to maximize airflow.
3. The range of your system needs to be increased. In the System Parameter Section, increase the range by one value. If your range was at 10, increase it to 12.

Question

New installation, the storm has left but I feel that too much time has gone by before I am given the ALL CLEAR signal. Is it possible to shorten the time? Or the ALL CLEAR signal sounds and then within 2–5 minutes, the RED ALERT is resounded.

Answer:

There is an adjustment that can be made. We would like you to call your area representative or THOR GUARD so the correct adjustments to your system can be made.

Technical Support

Questions & Answers

Question

How often do I clean the sensor? What liquid/chemical do I use?

Answer:

Depending on the geographic area, time of the year and location of the sensor, the cleaning can be quarterly or semi-annual. Areas with heavy pollen may require bi-monthly. Use only *water* and dry paper towels, as other liquids may leave a residue. Over time, you will develop the best time frame that fits your area.

Question:

The system says RED ALERT but the horns have not sounded. How do I sound the horns?

Answer:

1. If the display says “Alarm Off,” the L75 alarm is outside the System Alarm Time. The horns are deactivated and cannot be sounded.
2. If the system is in the (MAN) mode, the horns will not sound automatically. Press the **RED ALERT** key, horns should sound. You may have to manually press the **ALL CLEAR** key when the storm has passed.
3. Check “System Parameters,” and see what the “Alarm Mode” is set for and make adjustments if necessary.
4. Press the “Alarm Mode” and place the system to be in the “Auto” mode. This will allow the horns to sound automatically whenever the system determines a lightning threat.

Question:

L75 operates erratically, horns sound or display lock up?

Answer:

1. Is L75 connected to a UPS? Try bypassing UPS by directly connecting to AC outlet.
2. Try connecting UPS or L75 to a different AC outlet.
3. Motors, vending machine and water coolers produce heavy transients on AC lines which can affect the operation of your system.

Technical Support

Questions & Answers

Question:

When will I know the All Clear signal will sound?

Answer:

The AD or “Activity Detector” is a minute counter. It starts at ten (10) and when it reaches zero (0), the horns will sound with an ALL CLEAR. During the storm and as the storm leaves, the AD will reload with a specific value depending on the current DI and energy levels.

It is possible to have a DI of 1.5 and reload the AD to 5 or 10, depending on the energy. THOR GUARD must have the area being monitored safe before the ALL CLEAR condition is displayed.

Question

We need to relocate the L75 but the sensor cable is too short. Where can I buy additional cable?

Answer:

The cable used is of a triaxial type. THOR GUARD can supply you with a section of cable having the 6-pin Din connector pre- attached. Consult your representative or THOR GUARD.

Question

We ordered a sensor with 200 feet of cable, but changed our mounting location and only need 100 feet. What do I do with the excess cable?

Answer:

Contact THOR GUARD for the appropriate solution.

Technical Support

Questions & Answers

Question

My display and bar graph lights are out. Or the display is frozen. Where is the fuse? How do I reset the system?

Answer:

The L75 uses an internal self-resetting solid state fuse. Remove the power to the L75, either at the L75 or the power transformer. Re-attach after 10 seconds. Still no lights, check the UPS, check AC power and plug transformer directly to known live AC outlet. Measure voltage on transformer connector; it should be 18vdc.

Question

A storm is present and the current time is 7:05pm. My alarm active time is 8:00 am to 7:00 pm. What will the system do?

Answer:

All strobe lights if on, will turn off at 7:00 pm. The system will still monitor the storm, however no horns will sound. The local audio will be on, and depending on your setting, the local alarm will be active. You specify the time that THOR GUARD will provide you with audio (horns) and visual (strobe alerts).

Question

A storm in our area has been active for the last 1 /2 hour. The current time is 7:00 am. My alarm active time is 7:00 am to 7:00 pm. What will the system do?

Answer:

The L75 will show the current hazard and LHL and DI values. Depending on the alarm mode, AUTO or MAN, the RED ALARM alarm will sound. If installed, remotes will sound and the strobe light will turn on. The local audio will be on.

Technical Support

Questions & Answers

Question

Our application requires that we sound alarms 24 hours a day. Can we do this? and how?

Answer:

In the “Set L75 Default Alarm Time,” select the “Continuous Mode.” The horns and strobes will all operate regardless of the time. The display will indicate “24hr” or “Man” if selected. At the end of the day, 11:59 pm, the system will return to the default you selected in the “Alarm Mode.”

Question

The display switches between All Clear or Caution but I have an LHL of 4.0. The DI is 0.0 and there is no AD count. It has been this way for hours. What should I do?

Answer:

This is normal, as energy has moved into the area. There is no hazard at the present moment. A quantified discharge or activity must occur before THOR GUARD will trigger the AD.

THOR GUARD will discharge the sensor plate at periodic intervals. As the energy field dissipates, the LHL will return to zero (0).

When was the sensor last cleaned? This may also indicate a sensor cleaning is due.

Question

The hazard level went to Warning, then returned to All Clear. Is this normal?

Answer:

A storm developed in the distance, but the direction did not increase towards the monitored area. THOR GUARD’s unique prediction system determined that level of risk was not sufficient to sound the horns; go to RED ALERT.

The user may still decide to press the RED ALERT key and sound the horns if they wish to override the system.

Installation

Getting Started

Complete reading of the “Installation Portion” of this manual prior to component installation will ensure the successful operation of your THOR GUARD LIGHTNING PREDICTION SYSTEM.

The location of the L75, and optional VOTBD and base horns will be determined by numerous factors. Aesthetics, serviceability and audible coverage should govern the location for each component of the system.

Select where the L75 will be installed. The sensor directly connects to the L75. A viable path for the cable, not to exceed 200 feet must exist. The location for the sensor must follow the accompanying guidelines. Ensure that there is access to the sensor plate for required periodic cleaning.

AC power conditioners should be installed if poor regulation or the source of AC is deemed to be noisy. Connection to an irrigation line and vending machine circuits should be avoided.

If there is known AC power regulation problems, or you are subject to momentary brown-outs during electrical storms, a UPS (AC battery backup system) is recommended to maintain operation during these conditions. The failure to maintain AC will allow multiple sounding of the alarms to occur.

If there is a base horn (VOTBD) system included, a location for the horn driver enclosure must be determined. This fiberglass indoor/outdoor box (15.25”L x 13.5W x 7.5”H) can be a maximum of 200 feet from the L75. The horn cable has a limit of 40 feet.

The VOTBD should be located to allow access to service the battery or any parts of the system.

When installing a base horn, a 25W soldering iron will be required to attach the comm-link cable to the “pigtail” cable.

Have a question within the “Installation Portion”?

Contact THOR GUARD.

Installation

Supplies Required

L75 All Systems

Depending on the model of L75 you are installing, specific tools will be required. The method you select to secure the sensor to your facility and the path the cable will run will determine the type of fasteners (lag bolts) and mounting requirements (brackets, patio stones, galvanized pipe).

PVC cement is necessary to attach the pvc bushing to the sensor.

Silicon sealant or similar should be used to seal holes wherever the sensor cable passes through openings.

If required, mounting fasteners for the L75 should be acquired.

The sensor cable should be run connected as shipped. Cutting and splicing of the sensor cable should be done only if absolutely necessary.

Do not use “staples” to secure sensor cable in place.

L75B, L75R using VOT Alarm Systems

You will need a 25W soldering iron and 60/40 rosin core solder to connect cables. Wire strippers, wire cutters, assorted sizes of flat and Phillips screwdrivers, assorted socket wrenches, portable drill and drill bits, and electrical tape will be necessary to complete installation.

Mounting of the VOTBD, VOTRC and location of the horns will determine length of one-inch diameter galvanized pipe required and mounting hardware.

Wire nuts are not recommended and all connections must be soldered and properly taped.

Installation

Choosing the L75 Location / Power Requirements

Selecting 75 Location

The ideal location for the L75 should be where responsible personnel can monitor and press appropriate alarms / functions. Four mounting holes are provided for a direct wall mount.

The L75 should be mounted inside a facility. If outdoor mounting is required, a separate weather suitable box should be used.

If the L75 will control base horns, the maximum length of cable to the VOTBD is limited to 200 feet. The horns cable can be a maximum of 40 feet. ***Longer lengths of horn cable will reduce the sound output.***

Sensors with a cable length of 125 feet are shipped with most systems. If additional length is necessary, contact THOR GUARD. A maximum length of 200 feet can be ordered.

Power Requirements

A verified 110 volt, 60 cycle A/C power outlet for the power supply that is known and has been checked to be wired correctly and properly grounded.

- If your A/C power source does not have a grounded plug (3-way) then you will need to use the ground screw on the bottom panel of the L75.
- Avoid outlets that are connected to water coolers, vending machines or other high current / transients devices.
- During times of operation, the AC power source must be active.
- A UPS (AC battery backup system) is recommended to maintain operation during adverse conditions or “dirty” AC. Thor Guard can provide a system if required.

230v Applications Outside the United States

For continued safety, proper grounding of the L75 is required. The enclosed black wire must be connected from the ground screw of the L75 to a secure and permanent ground within your facility

Installation

Choosing the Sensor Location

The location of the sensor will be dependent upon the desired location of the THOR GUARD console, the type of existing roofing material, the design of the roof, and the proximity of other equipment that may adversely affect the performance of the system. If a roof location is not possible, the sensor can be mounted on a post or pole.

NOTE: SYSTEM PERFORMANCE WILL BE COMPROMISED UNLESS THE SENSOR IS MOUNTED WITH A CLEAR “VIEW” OF THE SURROUNDING SKY. ADJACENT TALL BUILDINGS CAN RESTRICT AIR FLOW, THEREBY REDUCING NOTIFICATION TIME. IF A SUITABLE LOCATION CANNOT BE FOUND, DO NOT INSTALL!

The following should be considered when locating the sensor:

- Within the standard 125-ft. cable length (200-ft. cable lengths available).
- At least 10 feet from lightning rods.
- At least 15 feet from (and higher than) air conditioning units, vents, fans, etc.
- At least 15 feet from other antennas; e.g. TV, VHF, etc.
- Never under overhanging trees and high power lines.
- Outside a 30-degree angle from building structures or trees (trees absorb energy from “storms”).
- As far as possible from electric chargers or transformers.
- A metal roof is not advisable, but if necessary, isolate the sensor tripod from the roof and elevate the sensor as much as possible.
- Locate high enough so that curious hands cannot inadvertently touch the sensor plate (located under the big dome).
- **MAKE SURE THAT ANY MAST OR TRIPOD UTILIZED TO MOUNT THE SENSOR IS NOT GROUNDED.**
- Sensor must be accessible for regular cleaning (See “Sensor Cleaning” page 29).

If you have any questions about your location, contact THOR GUARD prior to the installation of the sensor.

Installation

Mounting the Sensor

The sensor was designed to be mounted 5-10 feet above any surface using a 3-5' piece of one-inch rigid pipe with one end threaded. Longer lengths may be required in specific situations.

Remember that the sensor needs an unobstructed view, 360° of the atmosphere to allow maximum performance, and accessible for routine cleaning.

A threaded bushing is shipped separately to allow ease of assembly to the pipe. It is possible to use 1 - 1/2" PVC and cement directly to the sensor. (***THE BUSHING MUST BE GLUED INTO THE BOTTOM OF THE SENSOR PVC.***)

Set the sensor plate at a level that is accessible for cleaning, regardless of which type of mounting mast is utilized. Most installations will accept one of the following mounting techniques:

1. Mount directly to a wall using a pair of appropriate wall mounts (from Radio Shack or equivalent) and a short piece (3-5') of one-inch rigid pipe:

4" #15-883 8" #15-886 12" #15-885

2. Mount directly to pipe stub or antenna mast with stainless hose clamps.
3. Tripod (Radio Shack or equivalent): 3' #15-517
4. Use THOR GUARD Mounting Bar (optional) with single tripod setup for sensor and base horn and/or strobe light.

How the tripod is mounted depends upon the material and construction of the desired roof location. Use a minimum 3/8" diameter lag bolts and liberal amounts of waterproof silicone. Three 16" patio stones can be used to anchor the sensor to avoid roof penetration. Care should be taken if you choose to penetrate any roofing material. **DO NOT GROUND THE TRIPOD TO THE LIGHTNING ROD SYSTEM OR THE BUILDING.**

Installation

Running the Sensor Cable

The sensor uses a Outdoor rated Polyethylene Jacket cable. The connector on the cable which attaches to the L75 requires a 3/4-inch opening to pass through any opening along the route of the cable path.

If you are installing this cable in conduit, a minimum diameter of 1” should be used. Additionally, it may be required for you to cut the sensor connector off and splice the cable after installation.

You have been supplied with a predetermined length of sensor cable, which is connected to the sensor. At this time, determine the L75 location and ensure that there is sufficient sensor cable. The path available for the cable will also dictate the final location of the sensor and console.

If your system will be using a THOR GUARD VOT SYSTEM, determine the best location for the base horns and where the VOTBD will be mounted. Run the comm-link cable at the same time if the VOTBD is to be located near sensor. Apart from avoiding the obvious obstacles, attention should be given to the following:

- Do not cut sensor cable to shorten excess wire without discussing it with your representative or THOR GUARD.
- The sensor cable does not carry any AC power, so in most instances it will not be necessary to enclose it in conduit.
- When routing the cable, do not parallel lightning rod grounding wires or power runs and refrain from **tie wrapping to another cable of any type**.
- Avoid sharp bends, metal edges or anything that might tear or chafe the outer jacket.
- Avoid pulling too tightly and stretching or crimping the cable.
- Leave a minimum of 4 feet “service loop” when you mount the sensor.
- Use of staples to secure cable is not recommended.

Installation

Strobe Bracket & Strobe Light

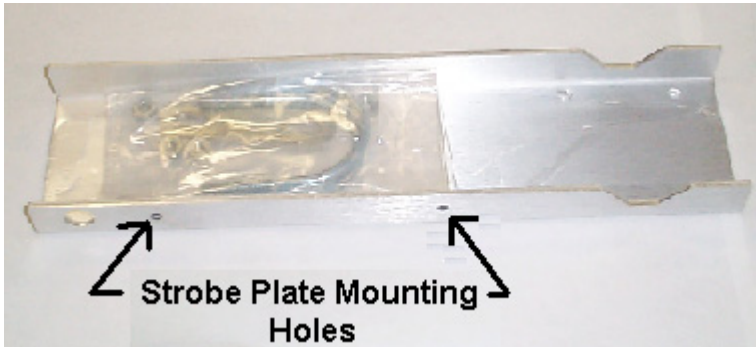

A strobe mounting bracket with two (2) U- Bolts may have been included to facilitate mounting the strobe at your location.

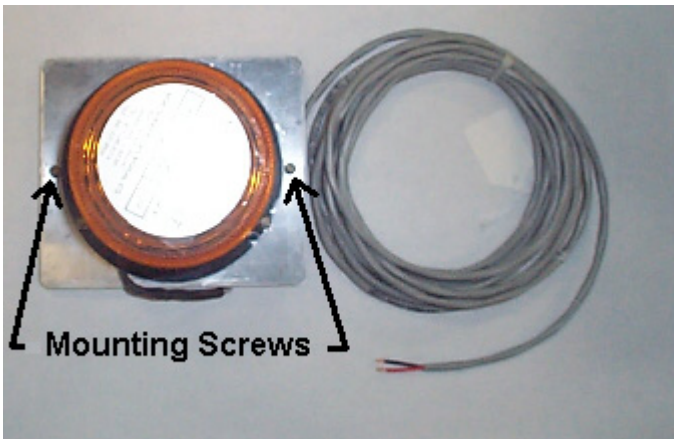

The strobe light is mounted to a plate. The plate will need to be attached to the mounting bracket. Two (2) plate-mounting screws (6-32 x 1/2) need to be removed and used to secure to the bracket.

Lengthening of the strobe cable can be done using approved cable.

Installation

Local Alarm /Strobe Cable

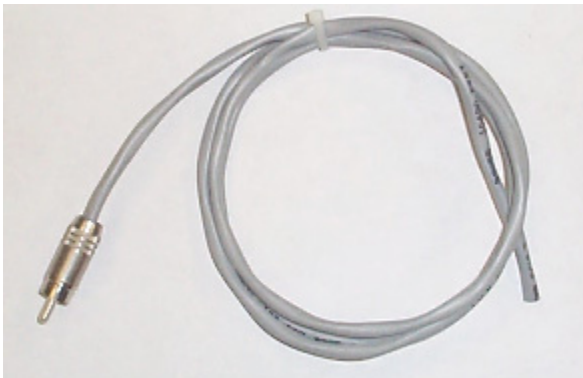

Each system may include a cable that allows access to the local alarm located on the top panel of the L75 (See Page 8). The output provides 12V DC @ 500ma. This can be connected to a light or buzzer or can be used to trigger an auxiliary +12v relay coil.

The red wire is positive (+12v) and the black is negative (ground).

Depending on the application, the user may need to increase the cable length.

Installation

VOTBD Comm-Link Cable at L75

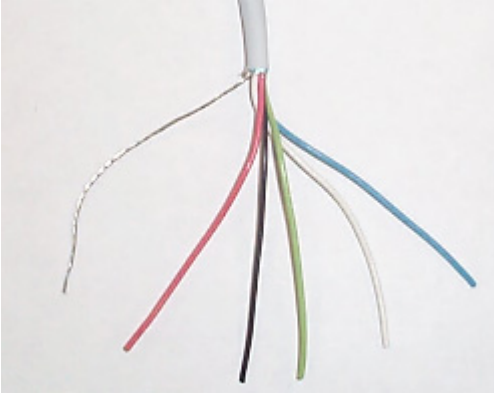

Prepare the comm-link cable as shown. Isolate the drain and the bare wire with no insulation to the side. The brown wire should be cut off. It will not be used.

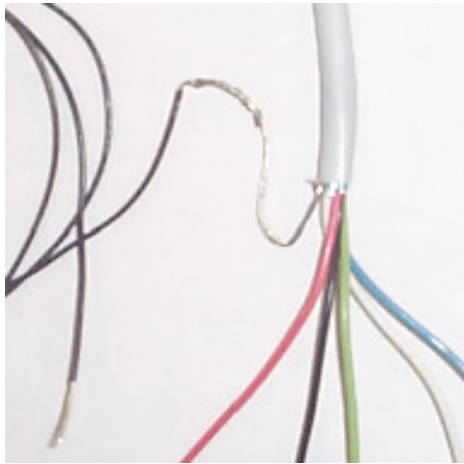

Connect one end of the supplied black grounding wire to the drain and solder the connection. The other end will connect to the center screw of the AC outlet. Wrap solder connection with electrical tape.

Installation

L75 Comm-Link Models B & R

The comm-link should not be connected to any components within the VOTBD (base horns, transmitter) at this time. Locate the VOT “pigtail cable” connect like colored wires of the pigtail cable to the comm-link cable that runs to the VOTBD. ***To ensure reliability, soldering each connection is required.*** Tape each wire individually.

Allow enough cable for a service loop.

Cut the brown wire in the comm-link cable and leave unconnected.

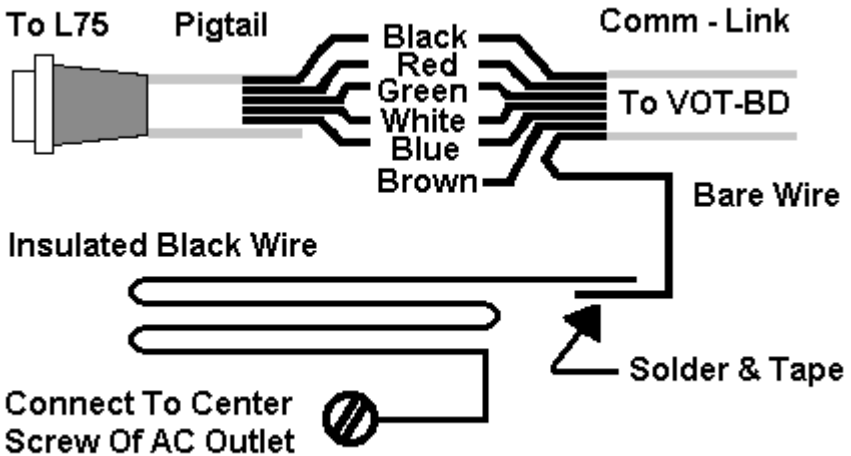

You can tape a 6–8” piece of comm-link cable to the entire solder connection to give support to the splice and serve as a splint.

Attaching shield to AC outlet is necessary and will prevent failures.

Do not attach the pigtail to the L75 at this time.

Installation

Mounting VOTBD & Horn Assembly

Securely mount the enclosure, either to wall studs, a concrete wall, a plywood backed surface, or use "c" clamps and attach to the tripod or mounting pole. A maximum distance of 40 feet from the horns is recommended. Longer lengths of horn cable will reduce sound output.

Attach the desired length of one-inch galvanized pipe, one end threaded to the enclosed reducing bushing, using care to avoid cross-threading.

Select the mounting technique, whether tripod or wall mount. Route the compressor cable down the pipe. Secure the horn cluster to the bushing using PVC cement. Allow enough cable for a 2-4 foot service loop.

Changing the positioning of the horns can alter sound coverage. Each horn can be re-positioned for optimal coverage by loosening the mounting bolt with a 3/8" wrench.

Run the horn cable to the VOTBD and pass through the bottom strain relief. Cut excess cable allowing for one foot inside the box.

Connect the horn cable to the four screw terminals on the relay board bracket. Match wires to correct colors indicated.

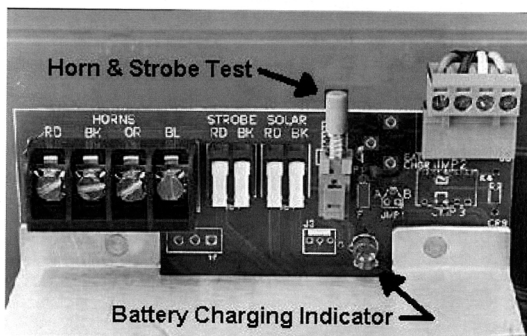

Installation

Mounting VOTBD Base RF Antenna

If your system will include remote horns, a base RF antenna will need to be installed.

Enclosed with the antenna are:

- (1) 27.255Mhz white tuned 4-ft. antenna.
- (1) 27.255Mhz white tuned 2-ft. ground plate.
- 18" aluminum mounting bracket with connectors attached.
- (2) "U" bolts to mount to 1" galvanized pipe.

(The 8-ft insulated wire is no longer used)

Secure the 4ft antenna into the top receptacle on mounting bracket. Screw the 2-ft. ground plane into the side of the bracket. Tighten with pliers.

The ideal location for the bracket is below the horn clusters. Using the "U" bolts, attach bracket to pipe and allow the antenna to pass between two horns. Unwrap the insulated 8-ft. wire and the antenna cable. Using tie-wraps, route and secure the RF cable and insulated wire down the outside of the pipe, leaving the insulated wire fully extended and not connected. This wire provides a matched ground plane for the antenna.

There are two mounting holes on the bracket in the event a strobe light is mounted. If so, attach strobe plate and route cable with RF cable. If included, route the strobe light cable into the box and attached to the top connectors of the relay circuit board.

The RF cable attaches to the bottom of the VOTBD. Insure that the center of the RF connector is fully seated. Erratic operation can occur if not seated correctly; tighten with pliers.

Installation

Comm-Link Cable at VOTBD

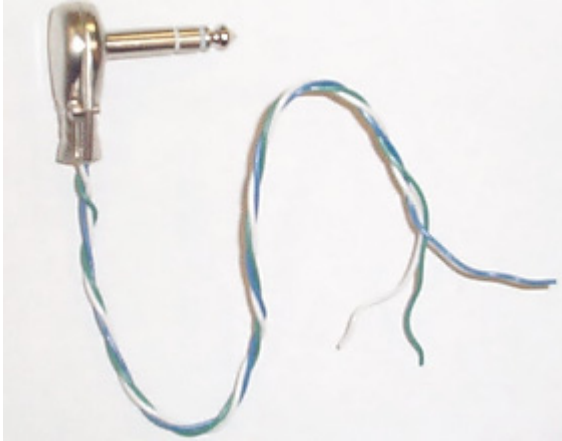

A transmitter to comm-link phone jack with wires is shipped with each VOTBD. This is enclosed with the VOTBD.



Prepare the cable by removing 12 inches of insulation. Cut the brown wire and the drain. Wrap the cable insulation where it enters the box with electrical tape to prevent any possible shorting.

Route the comm-link cable through the left strain relief. Strip insulation $\frac{1}{4}$ - $\frac{1}{2}$ " and secure the red and black wires to the top of the relay board in the location marked "Solar."

Installation

Comm-Link Cable at VOTBD, (Cont.)

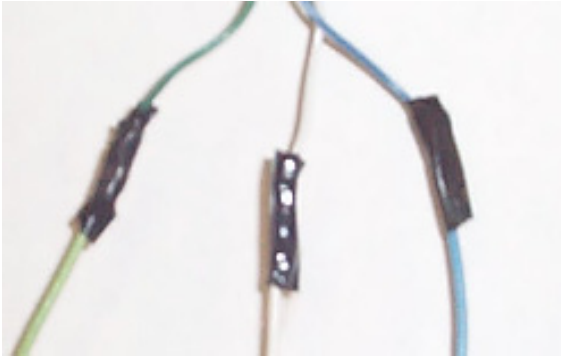

Route the green, white and blue wire towards the left side of the transmitter. Connect the “pigtail” to the comm-link cable, then apply sufficient solder. Tape each connection separately, followed by a wrap of all three wires together.

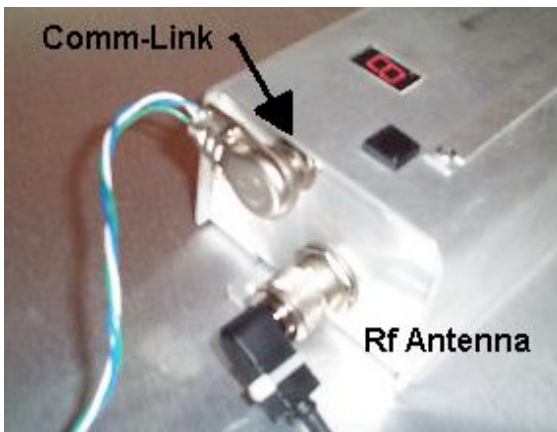

Insert the connector in the opening on the left side of the transmitter. Press connector firmly to ensure correct seating.

Installation

Battery Connect, Power Up

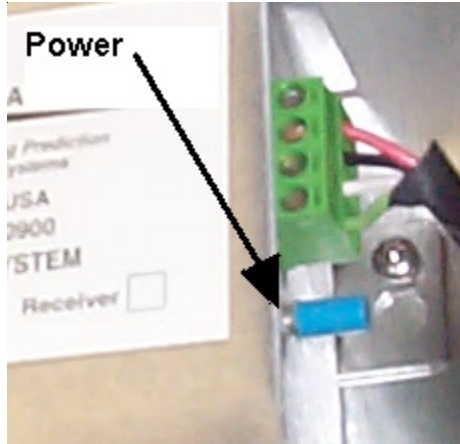

At this time in the installation, the comm-link cable at the L75 should have been soldered and taped. Do not continue until this has been done.

The VOTBD has been shipped with the black wire attached to the battery. It is now necessary to attach the red wire to the battery and tighten. Attach the red battery wire to the battery. Press the blue power switch on the transmitter (in = on, out = off) and the display should light. The display will show the software revision, followed by the Rf site code.

The display will change then blink a letter “E.” This indicates the L75 is not connected to the VOTBD or power maybe removed.

Return to the L75, attach the VOTBD cable to the L75, the “E” will change to a blinking “-“. This indicates the connection is good. The red light on the relay board will illuminate indicating the battery is receiving a charging voltage from the L75.

Installation

VOTBD & VOTRC Solar Assembly

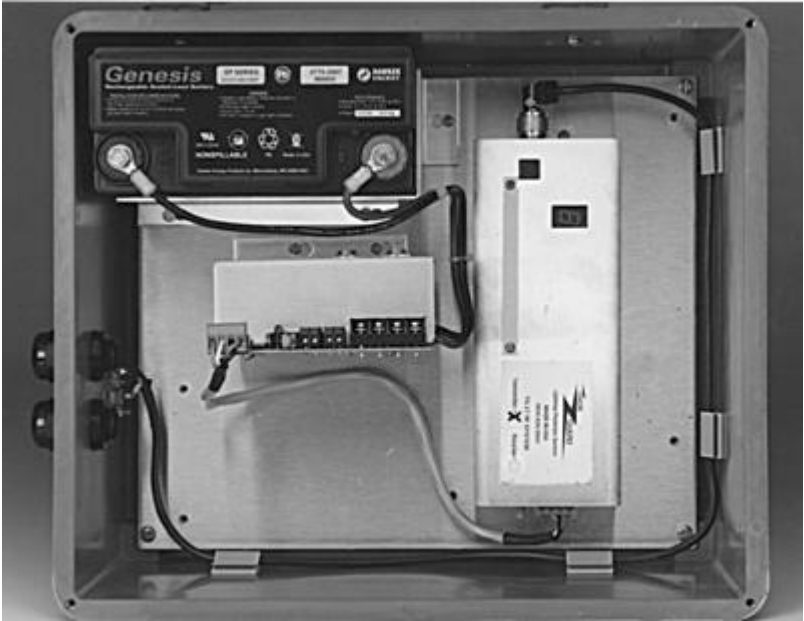

The VOTBD will use a TG27 transmitter. The VOTRC will use a TG27 receiver.

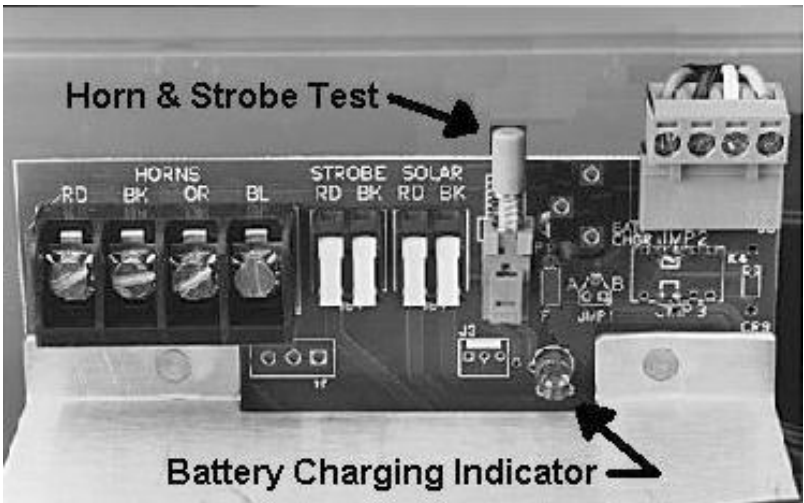

Installation

Preparing VOTRC & Horn Cluster

Any state or county electrical codes should be followed whether installing a solar or electric system. Protective covers for outdoor AC outlets should be used.

The location for each of the remote horns should have been selected. Ideally, there should be a “line of sight” between the RF antenna and the base. Installing horns under dense trees is not recommended as RF interference may occur when wet.

There are two types of remote systems, electric and solar. The availability of 115V AC and the selected location will determine which style of remote you ordered. The solar uses a 20W panel and will need a southern exposure to the sun to recharge the battery. Electric models come with a 5-ft. power cable for direct connection to an AC outlet. A reliable source of AC should be used otherwise a loss of battery charge will occur, thus causing the horn not to sound and damage to the battery.

Mounting techniques include a post or pipe mount, tripod, eave standoff, or whatever method allows for service of the battery.

During winter months, you may want to remove the battery to extend its life. Connect to a “trickle” charger.

The horn and RF cable will either be 18 or 40 feet, depending on your initial order requirement. The horn cable can be spliced, however, greater lengths will start to reduce the horn output level.

You will need a piece of one-inch galvanized pipe, one end threaded to secure to the horn cluster. Determine the length pipe needed based on the mounting technique, 10 to 15 feet from the ground. Going too high will result in a decrease in sound. The supplies required would include tools and PVC cement used when mounting VOTBD.

Installation

Mounting VOTRC, Horn Cluster, RF

Securely mount the enclosure, either to wall studs, a concrete wall, a 4X4 or 6X6 post, a plywood backed surface, or use "c" clamps and attach to the tripod or mounting pole. If using a solar panel, ensure a southerly exposure exists and there are no obstructions to block the sunlight.

Attach the PVC bushing to the pipe. Route horn cable inside pipe and secure bushing with PVC cement. Attach pipe to mount & install RF antenna and strobe light (optional). Extend ground wire along pipe with RF cable and secure with tie-wraps.

The RF antenna attaches similarly to the VOTBD (Page 54).

The strobe light uses two mounting holes on the RF bracket.

If using a solar panel, mount panel to bracket, then attach to post.

Attach RF cable to enclosure, tighten with pliers. Coil excess cable and secure with tie-wraps. Route horn cable and solar power cables through lower bushings, and cut excess horn cable, allowing for a one-foot internal service loop.

Secure horn cables to connector on bracket, observing colors. Insert solar wires to two-position input on relay board labeled "Solar." A red light indicating battery charging on the relay bracket should now be lit (Page 58).

Connect strobe wires to two-position input on relay board labeled "Strobe."

If electric model, turn power switch (circuit breaker) on; a green neon light should illuminate.

Attach red wire to battery. Press the blue button on the right side of receiver; power off is out, power on is in. To test the horns and strobe light, press and hold the black square button on the receiver for five seconds. You may also press the momentary blue switch on the top of the relay bracket.

Installation

Note: After placing the VOTRC-E in service, it is imperative that a grounded outlet is used and the AC plug is easily accessible after installation.

VOTRC Electric Assembly

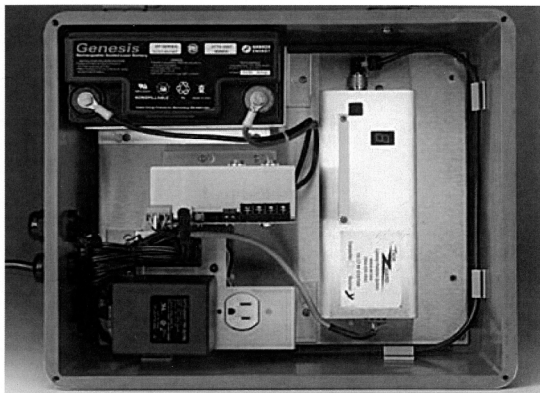

The VOTRC electric includes a 5-ft., 3-conductor power cord. Battery charging is done with an enclosed wall mount AC-DC transformer which connects at the top of the relay board.

NOTE: VOT relay boards for electric and solar models are not interchangeable.

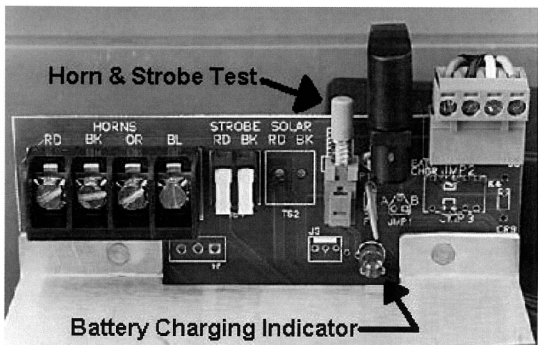

Installation

FCC Rules and Regulations – Compliance Statement THORGUARD TG27 FM VOT SYSTEM

The Transmitter and Receiver (components) that are used in the THORGUARD VOT System are covered by FCC Part 95 Radio Control Device. The components are designated for use in the United States and only those locations as authorized and permitted by the FCC.

There are no adjustments the user is authorized or permitted to make to alter the frequency or power of these components. The user is only permitted to change the Dip Switches for their location as assigned by THORGUARD. Any changes or adjustments to the Transmitter or Receiver can cause a violation of the Rules. Any and all repairs to the Transmitter and or Receiver, which could include but not be limited to the crystal or semiconductors, must be performed only by THORGUARD.

This equipment has been tested and found to comply with the limits of a Class A digital device, pursuant to Part 15, of the FCC Rules. These limits are designed to provide reasonable protection against harmful interference when the equipment is operated in a commercial environment. This equipment generates, uses and can radiate radio frequency energy and, if not installed and used in accordance with the instruction manual, may cause harmful interference to radio communications. Operation of this equipment in a residential area is likely to cause harmful interference in which case the user will be required to correct the interference at his own expense.

System Start Up

Sensor Check

L75 Sensor Cable Connections

Plug the black triaxial cable into the connector labeled SENSOR, on the topside panel. The black dot or gray plastic line should face towards the front of the L75.

Attach power transformer to the AC power or UPS and to the L75. After power is applied, you may be prompted to set the system time before a sensor check. Refer to Page 12.

L75 Sensor Check

To begin a sensor test, the energy level should be clear and there should be no DI present. If there is, remove power, wait ten seconds and reattach power. If energy returns and the A/D is now active, testing will be restricted.

Push and release the “**Test**” key, wait until the “Press Test” is displayed. Press “**Test**” and release. The display will indicate L75 Testing. The bar graph will display maximum positive & maximum negative energy during the test. After the test, the display will show the results of the test, Test (). Letter “P” indicates pass and letter “F” indicates fail. If sensor passes, continue to System Setup (Page 64).

If the letter “F” appears, disconnect power and remove the sensor plug and then insert the attached test plug, gray line up. Re-apply power and re-run the test to see if the problem is in the unit or in the sensor/cable run. If the letter “P” occurs with the test plug installed in the L75, then the problem is either the sensor or the cable. Check cable for chafing or kinks. Call THOR GUARD.

System Start Up

System Set-Up

If the display is indicating “Service Rf” at this time, ensure the VOTBD cable has been connected to the L75. Also check that the transmitter has been turned on (blue switch is in).

There are several default parameters that the user may wish to change if desired or required. Depending on the model L75 you have, some menu items will not apply.

Several parameters that you should now determine are:

<u>Parameter</u>	<u>Factory Default</u>
Determine the Alarms Time Active.....	7:00 am – 8:00pm
Select the Alarm Mode Auto or Manual	Auto
Select the Auto All Clear.....	Enabled
Select the Sensor Test Time.....	10:00am

Press **MENU** and then press the **MUTE/ENTER** key. Continue until the display indicates the parameter you need to change.

Each menu item uses the **CHANGE/TEST or MUTE/ENTER** key to either change a specific field or select the next field. At the end of the Menu options, you will asked to exit, press **MUTE/ENTER**.

System Start Up

Horn & Strobe Light

If your L75 was installed with a horn system or local strobe light, it should be checked.

Determine if a horn test can be done now and then notify necessary personnel that a THOR GUARD Lightning System horn test will occur. Distance of audible performance may want to be checked at this time.

Press the “**RED ALERT**” key and the local horns and remote horns will sound, and all strobe lights will turn on.

Press the “**ALL CLEAR**” key and the horns should sound for 5 seconds, 3 times and the strobe light will turn off.

You can only test the horn and strobe light when in the alarm’s active time of operation.

Horns Will Not Sound or Strobe Light Stays Off:

Locate blue horn test button on relay bracket. Press it, and horns will sound and the strobe light will illuminate. If not, check for correct horn wiring.

Measure battery for +12 volts when horn test button is being pressed. Replace battery if it is +10.5 volts or below when horns are active, or allow sufficient time for battery to recharge.

Confirm blue power switch on transmitter is in, LED display is on, metal phone jack connected (push in), red LED on relay bracket is illuminated (battery charge voltage). Check the VOTBD wiring and make sure the horn cable is attached correctly to the relay bracket.

Connect horn cables directly to battery, first horn set (red positive black negative) second set (orange positive, blue negative). Replace horn cluster and/or relay bracket board. To check strobe light, connect directly to battery observing correct polarity.

WARRANTY

(Does not apply to products supplied by third-party vendors)

THOR GUARD, INC. (“the warrantor”) will repair the L75 product manufactured by the warrantor with new or refurbished parts, free of charge, subject to shipping charges in the USA for two (2) years from the date of original purchase in the event of a defect in material or workmanship. This warranty is extended only to the original purchaser and only covers failures due to defects in materials or workmanship that occur during normal operation. It does not cover damage that occurs in shipment or failures that are caused by products not supplied by the warrantor or failures that result from accident, misuse, abuse, neglect, mishandling, misapplication, alteration, modification, lightning, line power surge, introduction of sand, dust, humidity and liquids or commercial use of this product, or service by anyone other than a THOR GUARD factory or authorized representative, or damage that is attributable to “Acts of God.”

Selective installations located outside the United States are warranted for one (1) year, subject to shipping charges and include the above restrictions that may cause damage or failure.

In the event of a problem, please direct all inquiries to THOR GUARD, INC., 1193 Sawgrass Corporate Parkway, Sunrise FL 33323, Telephone: (888) 571-1212, or Fax: (954) 835-0808, or e-mail: service@thorguard.com.

The warranties of merchantability and fitness for a particular purpose are limited to the applicable warranty period set forth above.

Some states do not allow the exclusion or limitation of incidental or consequential damages, or limitations on how long an implied warranty lasts, so the above exclusions or limitations may not apply to you.

This warranty gives you specific rights and you may also have other rights, which vary, from state to state. If a problem with this product develops during or after the warranty period, you may contact your representative or our General Offices in Sunrise, Florida. There are no express warranties.

LIMITS & EXCLUSIONS

THE WARRANTIES ON PRODUCTS PURCHASED FROM THIRD-PARTY VENDORS WHICH INCLUDE BATTERIES, STROBE LIGHTS, UPS AND SOLAR PANELS ARE COVERED FOR A PERIOD OF ONE YEAR BY THOR GUARD.

AFTER ONE YEAR, THE WARRANTY ON THESE PRODUCTS IS THE RESPONSIBILITY AND SUBJECT TO THE INDIVIDUAL LIMITATIONS OF EACH MANUFACTURER.

THE SENSOR ASSEMBLY, WHICH INCLUDES THE CABLE, IS COVERED FOR A PERIOD OF ONE YEAR.

THE TRANSMITTER, RECEIVER, AIR HORN ASSEMBLIES, RF ANTENNAS AND CABLES, STROBE AND PC BOARD ASSEMBLIES USED IN THE VOTBD SYSTEM ARE COVERED FOR A PERIOD OF TWO YEARS.

THE WARRANTOR SHALL NOT BE LIABLE FOR INCIDENTAL OR CONSEQUENTIAL DAMAGES RESULTING FROM THE USE OF THESE PRODUCTS, OR ARISING OUT OF ANY BREACH OF THIS WARRANTY. ALL EXPRESS AND IMPLIED WARRANTIES, INCLUDING THE WARRANTIES OF MERCHANTABILITY AND FITNESS FOR A PARTICULAR PURPOSE, ARE LIMITED TO THE APPLICABLE WARRANTY PERIOD SET FORTH ABOVE.

L75 SOFTWARE WARRANTY

Thor Guard may modify the functionality and operation of the L75 or the software without notice. Any changes that are made to the software will exempt current installed systems requiring immediate software replacement.

Systems outside the software warranty period will be quoted the fee required to install any upgraded software.

All shipping costs, both during and after the warranty period, to install the software will be the responsibility of the customer.

All rights reserved. No part of this document may be reproduced in any way without the expressed written approval of THOR GUARD.

Copyright 2005 THOR GUARD, Inc., Sunrise, Florida.

NOTICE TO USERS

The THOR GUARD Lightning Prediction system is manufactured by THOR GUARD, Inc., for the express purpose of assisting the user in determining and evaluating the existence and extent of a potential for lightning discharges in the area being monitored by THOR GUARD. This product is in no way intended, nor is it represented to be, any form of protection for persons or property whatsoever; and THOR GUARD, Inc., shall not be held liable for any damages or losses the user may experience from the effects of lightning, storm related damages or personal injuries.

The THOR GUARD system will automatically test every day at a pre-selected time. It is the user's responsibility to ensure the system is connected to a properly grounded source of power and that the unit displays a (P) following its test. If the test should fail, the user, after immediately following the "Testing & Cleaning" instructions in this booklet to solve the problem, should call THOR GUARD, Inc., at the number provided below.



1193 Sawgrass Corporate Parkway
Sunrise, Florida 33323

(954) 835-0900
service@thorguard.com

Specifications

Models:	L75, L75B, L75I, L75R
Model Specifications:	L75 . . . Local Hazard Output, +12 Volt DC L75B . . . Local THOR GUARD VOT Base Horn L75I . . . Two (2) Separate Dry Closure Relays L75R . . . Local THOR GUARD VOT Base Horn & Remote Horns
L75 Power Requirements:	Voltage: 120 Volts AC, 60 Hz, Single Phase Power: .25A, 22 Watts
L75 Power Supply:	3-Plug, Wall Mounted, Grounded 120 VAC, 60 Hz Dimensions: 2.68" W x 2.19" D x 3.45" H Safety Requirements: UL, CSA Power Cord: 6 ft. Weight: 1.5 Lbs.
L75 Console:	Dimensions: 7.25" L x 8.75" W x 1.75" H Weight: 2 Lbs. Safety Requirement: CE
Hyperstatic Sensor:	Dimensions: 16" W x 30" H Weight: 7.5 Lbs. (Cable not Included)
Sensor Cable:	West Penn 5992, Outdoor Rated Polyethylene Jacket 3/8" Dia. Double Shielded Triaxial With Teflon Core Standard Length 125ft., 40ft., 75ft., or 150ft. Available. (200ft. Max Length, Additional Cost)
Vot Comm - Link Cable:	West Penn AQC 3186 Outdoor Rated UL Listed Nec Type CL3. 5/16" Dia. Shielded 18 AWG, 6 Conductor Sunlight And Moisture Resistant PVC Jacket. Standard Length Available 75ft., 125ft., 150ft. (200ft. Max Length)
Strobe Cable:	West Penn AQ224, Outdoor Rated UL Listed Nec Type. FPL or PLTC. 1/4" Dia. 18 AWG, 2 Conductor Sunlight And Moisture Resistant PVC Jacket.
Horn Cable:	American Insulated Wire 20885, Outdoor Rated UL / OSHA Listed. 7/16" Dia. 12 AWG, 4 Conductor. Direct Burial And Sunlight Resistant PVC Jacket.

(Specifications & features subject to change without notice)

Environmental Specifications

Operating Temperature Range: 0° to +110° F (-18° - 43° C)
Storage Temperature Range: -10° to +120° F (-23° - 49° C)

Humidity: 0 - 65% Non- Condensing
Wind Load: N/A

IMPORTANT

The L75 is restricted from being mounted in the outdoors without using a weather suitable box.