

SARASOTA HIGH SCHOOL



Program of Studies **2025-2026**

2155 Bahia Vista Street
Sarasota, FL 34239
P (941)955-0181 F (941)361-6380

<http://sarasotacountyschools.net/schools/sarasotahigh/>

Sarasota High School
2155 Bahia Vista Street
Sarasota, FL 34239
Phone (941) 955-0181 • Fax (941) 361-6380



Dear Parents and Students,

This High School Program of Study booklet is intended to provide valuable information to allow you and your parents to make selections that will best prepare you for future success. It has been designed to explain the rich variety of challenging and rigorous choices available to you.

Of special note, Sarasota High School is most pleased to be an official Cambridge AICE School! The Cambridge AICE (Advanced International Certificate of Education) program provides a high-quality diploma which prepares young people for honors degree programs and offers students the opportunity to tailor their studies to their individual interests, abilities, and future plans within an international curriculum framework. Please check our SHS website for additional information: <http://www.sarasotacountyschools.net/schools/sarasotahigh/>

In general, I encourage you to work with your teachers and counselors to make decisions appropriate for achieving your individual goals. We are continuing to explore ways to introduce more rigor, relevancy, diversity, and specialization to our high school course offerings. (Our Guidance Counselors will be able to fully explain courses that are implemented after the publication of this booklet.)

The choices you make regarding how you spend your time in school can make your future better and your goals more attainable. As Principal, I urge you to take full advantage of the courses that are provided at Sarasota High School. Your success is our greatest achievement, and we are committed to your continued development.

Please carefully review the information about the requirements for graduation. As a family, please make the most appropriate choices for your student. When selecting courses, please keep in mind what your ultimate goals are and how courses can fit into that plan. Those students who plan effectively and take advantage of the programs offered at the school, are the students who are best prepared for success after high school.

It is our pleasure to work with students as we “create a learning environment that is challenging, relevant and active to ensure our students are equipped for success in their post-secondary pursuits.”

Go Sailors!

Warmly,

Mr. Ryan Chase
Principal

TABLE OF CONTENTS

PART I: GENERAL INFORMATION	PAGE
ADMINISTRATION AND GUIDANCE TEAM	3
GRADUATION REQUIREMENTS	4
DISTRICT PROMOTION POLICY, GRADING POLICIES, GPA, AND CLASS RANK	5-6
ATHLETIC ELIGIBILITY	7
BRIGHT FUTURES, REGISTRATION INFORMATION, REGISTRATION PROCESS, STUDENT SCHEDULES, STUDENTS WITH DISABILITIES, ANCHOR PROGRAM, SARASOTA VIRTUAL ACADEMY, AND LAUNCH YOUR PLAN	8-9
MAGNET PROGRAM: AICE / UNIVERSITY OF CAMBRIDGE INTERNATIONAL EXAMINATIONS	10-11
MAGNET PROGRAM: MaST RESEARCH INSTITUTE	12
MAGNET PROGRAM: CIRCUS ARTS PROGRAM	13
DIPLOMA OPTIONS	14
COURSE LEGEND	15
PART II: COURSE DESCRIPTIONS	
ENGLISH LANGUAGE ARTS	16-22
MATHEMATICS	23-27
SCIENCE	28-33
SOCIAL STUDIES	34-39
WORLD LANGUAGES	40-41
CAREER AND TECHNICAL EDUCATION (CTE)	42-46
JROTC	47
VISUAL ARTS	48-51
PERFORMING ARTS	52-57
PHYSICAL EDUCATION	58-59
ACCESS DIPLOMA PROGRESSION	59
DUAL-ENROLLMENT OPTIONS	60

Sarasota High School
2155 Bahia Vista Street, Sarasota, FL 34239
(941) 955-0181 • Fax (941) 361-6630

Administration

Ryan Chase, Principal
Lindsay Gallof, Assistant Principal - Curriculum
Robin Livingston, Assistant Principal – Administration
Alana Pietranton – Assistant Principal ESE
Holly Hultgren, Assistant Principal, A-F
Brooke Teal, Assistant Principal, G-M
Jason Jackson, Assistant Principal, N-Z

School Counselors

Ciara Van Ness, A-F
Kim Dwyer, G-M
Cindy Rasmussen, N-Z
Caitlin Summerford, ESE
Katy Corban, AICE Grades 9-10
Lauren Taylor, AICE Grades 11-12

Instructional Support Staff

Ed Volz, ESOL Liaison
Shannon Nelson, ESE Liaison
Mark Rupprecht, ESE Liaison
Nina Singleton, Behavior Specialist
Brian Graham, Behavior Specialist
Jeffi Westberry – At-Risk Coordinator

GRADUATION REQUIREMENTS

	Credits
ENGLISH Major concentration in composition and literature.	4
MATHEMATICS Two credits must include Algebra 1 and Geometry.	4
SCIENCE One credit must include Biology. Two of which must have a laboratory component.	3
SOCIAL STUDIES World History, United States History, Economics & Government.	3
PRACTICAL/PERFORMING/FINE ARTS	1
HOPE - Health & Personal Fitness	1
ELECTIVES (must include Financial Literacy Course)	10
<hr/>	
TOTAL CREDITS	26

ADDITIONAL REQUIREMENTS

- ✓ Students must achieve passing scores on the **Algebra I End-of-Course Exam (EOC)**.
- ✓ Students must achieve passing scores on the 10th grade **FAST READING EXAM**.
- ✓ Students must achieve a cumulative grade point average of **2.0 on a 4.0** scale.
- ✓ At least one Financial Literacy course within the 26-credit program for Cohort 2027 and beyond
- ✓ The final grade for U.S. History, Algebra 1, Geometry, and Biology 1 or an equivalent course must include 30 percent of the EOC Assessment.
- ✓ While not a graduation requirement, Florida Bright Futures Scholarship and most four-year Colleges & Universities require two years of the same foreign language.

DISTRICT PROMOTION POLICY

To be Promoted to	Required Credits Earned	Courses Required
10 th Grade	4	
11 th Grade	11	1.0 English and 1.0 Math
12 th Grade	17	2.0 English and 2.0 Math

CREDIT:

Students will be awarded credit in a course for which there are school board adopted performance standards when mastery has been demonstrated.

60% (D) is required to pass a course.

End-of-Course (EOC) assessment requirements for Algebra I, Geometry, Biology, and U.S. History

Students may be awarded half credit in a full credit course if the final average is failing (59% or below) and one of the two semester averages is passing (60% or above). Students should see their counselor to arrange a makeup of credit shortages. **If the student elects to repeat the entire course, a total of one credit is the maximum credit awarded.**

GRADES: The following guidelines are used in the construction and implementation of the grading system for all Sarasota high schools.

Please Note: The Bright Futures GPA calculation utilizes specific courses and a different formula. Numeric grades will be reported along with the letter grades on the report card.

QUALITY POINTS

LETTER GRADE	DESCRIPTION	NUMBER RANGE	UNWEIGHTED	WEIGHTED (1.0 or 1.5)
A	EXCELLENT	90 - 100	4	5 or 5.5
B	ABOVE AVERAGE	80 - 89	3	4 or 4.5
C	AVERAGE	70 - 79	2	3 or 3.5
D	BELOW AVERAGE	60 - 69	1	2 or 2.5
F	FAILING	0 - 59	No Credit	No Credit
P	PASS	Credit	0	0
I	INCOMPLETE	N/A	0	0
W	WITHDRAWN	N/A	0	0

EMPLOYABILITY:

In each course twenty percent (20%) of the grade will be based on employability skills. Those skills will include:

- Attendance/Punctuality
- Bringing required materials, such as paper, pen/pencil, textbooks, notebooks, etc.
- Organization
- Completion of homework
- Appropriate dress for class
- Attitude of cooperation with teacher and fellow students
- On-task behavior in classroom

GRADE FORGIVENESS POLICY

Students are limited to replacing a grade of “D” or “F” with a grade of “C” or higher earned subsequently in the same or comparable course for those courses that are required for graduation. Forgiveness for elective courses is limited to replacing a grade of “D” or “F” with a grade of “C” or higher earned subsequently by retaking the same or comparable course or another course. Students who receive high school credit in middle school may retake the course(s) if he or she receives a final grade of “C” or below.

*Both final grades will appear on the student’s high school academic transcript, but only the higher of the two grades will be included in the calculation of the student’s grade point average. **Note that the Florida High School Athletic Association has its own policy for grade forgiveness for athletes.***

GPA:

You must earn a minimum of a 2.0 GPA on a 4.0 scale to graduate. Some courses are weighted (given extra points); however, the required 2.0 GPA is on an unweighted scale. Your GPA is very important for determining graduation and eligibility for special scholarship and extra-curricular activities such as sports. The GPA represents the number of quality points earned divided by the number of credits attempted.

Please note: Starting in the 2018-2019 school year, All Advanced Placement (AP), International Baccalaureate (IB), Advanced International Certificate of Education (AICE), and Dual Enrollment (DE) courses will have a 1.5 weight. All other Level 3 (honors) courses will have a 1.0 weight.

Quality points are assigned as follows:

Regular Courses	Honors, Level 3, & Pre-AICE Courses	AICE, AP, & Dual-Enrollment Courses
A = 4	A = 5	A = 5.5
B = 3	B = 4	B = 4.5
C = 2	C = 3	C = 3.5
D = 1	D = 2	D = 2.5
F = 0	F = 0	F = 0

CLASS RANK:

Class Rank is calculated by using all final grades earned through high school courses. All grades in credit subjects are included in computation of class rank, unless otherwise indicated on the student’s permanent record. GPA and class rank are recorded and reported as: “District” (the Weighted GPA) and “State” (the Unweighted GPA) on the student’s transcript.

HOMEWORK:

Homework is a regular part of the instruction process. Teachers are responsible for assigning homework commensurate with course content as well as the maturity level and needs of individual students.

INTERSCHOLASTIC EXTRACURRICULAR STUDENT ACTIVITIES ELIGIBILITY:

Sarasota High School offers many kinds of co-curricular and extra-curricular activities. Co-curricular activities are student organizations or groups that meet as part of a course or major area of interest. Examples include marching band and a wide variety of student organizations related to career interests. Students interested in a military career may also wish to consider enrolling in the JROTC program. Extracurricular activities include a large variety of sports programs for all students, school newspaper and yearbook.

ATHLETIC ELIGIBILITY:

At Sarasota High school, athletics are important extracurricular activities. Student athletes must also maintain good grades and attendance. There are also expectations for students who plan to pursue athletics at a college or university.

Our school provides a well-balanced program of interscholastic athletics for as many high school students as possible. The program is designed around available facilities, personnel, and financial support. Athletic activities are considered part of a quality physical education program and operate under the policies of the Sarasota County School Board and the Florida High School Athletic Association.

A student will be eligible during the first semester of his/her ninth-grade year provided that it is the student's first entry into the ninth grade, and he/she was regularly promoted from the eighth grade the immediate preceding year. Second semester ninth graders will be required to maintain a 2.0 minimum GPA for athletic participation. The minimum 2.0 grade point average is established in Florida Statutes and cannot be waived by the Florida High School Athletic Association.

NAIA ELIGIBILITY:

College bound athletes who plan to attend a National Association of Intercollegiate Athletes (NAIA) school will need to meet the following three admission requirements:

1. A minimum score of 18 on the Enhanced ACT or a combined 860 on the critical reading and math sections of the SAT.
2. An overall high school GPA of 2.0 or higher on a 4.0 scale.
3. Graduate in the upper half of his or her high school class.

NCAA ELIGIBILITY:

If you plan to be a college athlete in a Division I and Division II college or university, you will need to meet NCAA Clearinghouse standards as well as college admission standards.

For more information regarding eligibility, please visit:

http://fs.ncaa.org/Docs/eligibility_center/Quick_Reference_Sheet.pdf

For more information regarding the rules, please go to www.ncaa.org.

FLORIDA BRIGHT FUTURES:

Florida Bright Futures Scholarship Program awards scholarships to any Florida high school graduate who merits recognition of high academic achievement and who enrolls in an eligible Florida public or private post-secondary educational institution within three years of high school graduation.

There are three Florida Bright Futures Scholarships: Florida Academic Scholarship, Florida Medallion Scholarship and the Career Technical Education Gold Seal Scholarship. Students can qualify for only one scholarship and must meet certain requirements. The general requirements are:

- Florida residency
- Standard high school diploma with GPA requirement
- Accepted and enrolled in an eligible Florida public/private post-secondary school
- Enrolled for at least six semester credit hours during senior year
- Participate in community service
- Applied for the scholarship and FAFSA before graduation
- Qualifying scores on the SAT or ACT as set by Florida legislature

For more information regarding Bright Futures requirements, please visit the website at <http://www.floridastudentfinancialaid.org/SSFAD/bf/bfmain.htm>. The requirements for the Florida Bright Futures Scholarship program are subject to change at any time.

REGISTRATION INFORMATION:

When considering course selections, the following items may help students plan a schedule which meets individual interests and needs:

1. The Program of Studies is on the school website for further information on course descriptions. If you need more information, ask a teacher in the department or a guidance counselor.
2. A "D/F" grade is a very insecure foundation for building success in a sequential course. If a student receives a "D/F" grade and wishes to continue such a course, we advise consulting with the teacher of the current course.
3. Check credits carefully for those already earned and those still needing to be earned. Be certain to schedule the credits necessary for graduation. If in doubt, see a counselor.
4. Students should choose challenging courses appropriate to their individual strengths and abilities.

REGISTRATION PROCESS:

1. The Program of Studies will be on the school web site for further information. The registration sheets will be given to the students. Students will discuss courses with parents and teachers. Students must get teacher approval when necessary.
2. Counselors will meet individually with students to review course selections and answer any questions.
3. Students failing to complete the **SPRING** registration will have their courses selected by a counselor.
4. FAST, BEST, EOC and/or PSAT results may be used in some course placements.

STUDENT SCHEDULES:

Student schedules identify the courses to be taken, class period, teacher name and room.

After the school year begins, schedule changes require administrative approval.

When registering, students should give careful thought to the choices they make, BECAUSE, based on their choices, classes are formed, textbooks, materials and supplies are ordered, and teachers are assigned.

IMPORTANT NOTE:

It is the responsibility of students to ensure that they are meeting all graduation requirements. Students, parents, and guardians are strongly encouraged to work closely with school counselors to ensure that you are maintaining a course of study that will enable you to meet all graduation requirements.

STUDENTS WITH DISABILITIES (SWD):

Special programs and accommodations are available to meet the needs and abilities of our students with disabilities. Students may receive support, accommodations, and instruction in Exceptional Education courses or general education courses based upon individual needs.

SARASOTA HIGH ANCHOR ACADEMY:

The Performance Based Program is an alternative education program designed to assist students with their high school diploma. The Performance Based Program is offered as part of the overall comprehensive dropout efforts of the School District of Sarasota County. Your school counselor can discuss eligibility requirements with you and your family.

SARASOTA VIRTUAL ACADEMY:

Sarasota Virtual Academy allows students to take a variety of courses online at their home school. The online learner takes the class in our state-of-the-art Global Learning Center. Sarasota County teachers make school visits and provide a personalized online experience. Students will receive applications during the course selection process. The student returns the form to the high school counselor to take a course. Please visit the Sarasota County website:

<http://sarasotacountyschools.net/students.aspx> to watch an informational video about the program.

Please note: Signing up for an online class does not guarantee a spot on campus to complete.

Student seats are administratively determined.

LAUNCH YOUR PLAN:

Supported by the Education Foundation of Sarasota County, Launch Your Plan is an online resource to help students create a plan for college and career options. Please visit for more information:

<https://launchyourplan.com/>



Cambridge AICE Diploma Explanation

The Cambridge AICE Diploma is a group award that recognizes the achievements of students who have experienced the balanced and stimulating curriculum of Cambridge International Advanced Subsidiary Level (AS Level) and Advanced Level (A Level). The diploma program was launched in Florida, USA in 1997, where it continues to receive strong legislative support and funding. Now, used by schools around the world, the Cambridge AICE Diploma is evolving to make sure it continues to prepare students for success at college and beyond.

Preparing students for college success:

Along with in-depth understanding of their subjects, students also need to master a broader range of skills critical for success in university study and employment. The Cambridge AICE Diploma is changing to place more emphasis on essential skills such as the ability to:

- think critically
- carry out independent research and evaluate arguments
- communicate clear and well-reasoned arguments
- understand global issues from multiple perspectives.

This evolution will help higher education institutions identify students with the type of cohesive academic experience and higher-order thinking and communication skills that are associated with distinguished achievement at university.

Thinking critically, independently, and globally are the core of the diploma. To achieve the diploma all learners will need to study and pass the Cambridge International AS Level Global Perspectives curriculum. This skills-based course challenges learners to think critically, analyze evidence and compare perspectives. The curriculum is assessed through a range of options, including a written examination, team project and presentation.

The course is built around an innovative teaching and learning process called the Cambridge critical path. This supports learners to think critically and objectively, leading to a deeper understanding of their chosen topic. A rigorous and stimulating program that ensures breadth and depth The Cambridge AICE Diploma is designed to deliver breadth across the curriculum and depth in selected subjects. Learners must achieve a minimum of seven credits from at least three subject groupings and the core (Cambridge International AS Level Global Perspectives) to be awarded the diploma.

Within the diploma a Cambridge International AS Level examination passing score is awarded one credit and a Cambridge International A Level examination passing score is awarded two credits.



In the fall of 1995, the School of Excellence in Math, Science, and Technology (MaST) was established at SHS (Sarasota High School). The MaST Research Institute (MRI) operates as a school-within-a-school and is intended to provide qualified students with a rigorous enriched curriculum to prepare them for entry into Math, Science, Medical or Engineering related careers following high school. The MaST Research Institute offers students a competitive edge when applying to university degree programs.

WHAT SETS US APART?

- Variety of faculty specialties
 - Microbiology/Cells/Health
 - Engineering
 - Physical Sciences
 - Beyond!
- State-of-the-Art Lab
 - Biosafety Level 2 Certified
 - Only high school in the area able to conduct advanced cell culture & microbiology projects
- Strategic fundraising to purchase research materials and advanced equipment
 - Ultrasonicator, cell culture incubator, 3D printer, and more!

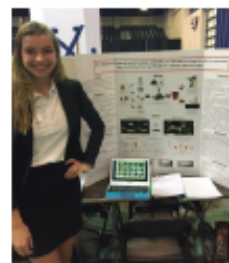
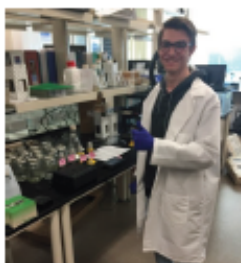

ADVANCED COURSE OFFERINGS

The MaST Research Institute is proud to be a part of the AP Capstone program, which will provide our research students with up to 6 college credit hours for their research progression as well as the opportunity to earn the AP Research & Seminar Certificate, which holds the equivalence of AP Scholar status. In addition, Sarasota High provides AICE courses that allow students to earn college credit in Calculus, English, Biology, Chemistry, Environmental Management, Marine Biology, American History, American Government, and many more, all of which have consistently high passing rates.



Cambridge International School

POINTS OF PRIDE

- MaST Research Scholars have continually been admitted to top Universities
- MaST students continually win the most place awards Sarasota County Regional Science Fair
- Students selected to major competitions such as the State Science and Engineering Fair of Florida, the Florida Junior Academy of Sciences Conference, and the Junior Science Engineering and Humanities Symposium
- Top MaST students are frequent competitors in the International Science and Engineering Fair
- Graduates of MaST have become:
 - Beckman Scholars
 - Ivy League Graduates
 - Chemical Engineers
 - Graduate Students and PhDs
 - Nuclear Engineers
 - Doctors and Nurses
 - Marine Scientists



Sarasota High School
2155 Bahia Vista St.
Sarasota, FL 34239

Phone: 941-955-0181

Fax: 941-361-6380

E-mail:

john.stevenson@sarasotacountyschools.net

andy.harshman@sarasotacountyschools.net

For more information and to apply,
please visit: www.shsmri.com

Circus Arts Magnet Program

Sarasota High School is excited to reestablish the Circus Arts Program! Sarasota, FL is steeped in the history of the circus arts. The original Sailor Circus grew out of an extension of courses at Sarasota High in 1949. In partnership with the Circus Arts Conservatory, SHS established a student choice/magnet program for the students of Sarasota County. Many of our high school students across the district are active members of the Sailor Circus. By combining academic rigor and focus with our students' passion for the circus arts, Sarasota High School is preparing students for a future with unlimited potential.

- Through an application and audition process, students will be placed in either an introductory/beginner level or an intermediate/advanced level. Applications are available on our school website: <https://sarasotacountyschools.net/schools/sarasotahigh/>

- Students in the program will participate in a two-period block to allow for instruction, practice/application, feedback, reteaching, and reassessment of skills.

Circus Magnet Proposed Course Progression	Semester 1	Semester 2
Exploratory - Intro to Circus (any grade 9/10)	Gymnastics 1	Gymnastics 2
Magnet Year 1 - Introductory Coursework		
4th period	Care and Prevention of Athletic Injuries	Fitness Lifestyle Design 1501310
5th period	Dance Repertory 1 0300400	
Magnet Year 2 - Intermediate Coursework		
4th period	Dance Repertory 2 0300410	
5th period	Pre-AICE Physical Education	
Magnet Year 3 - Advanced Coursework		
7th period	Dance Repertory 3 Hon 0300420	
8th period	Dance Choreography 1 0300380	
Magnet Year 4 - Advanced Coursework		
7th period	Dance Repertory 4 Hon 0300430	
8th period	Dance Choreography 2 0300390	

- Students will earn their high school diploma meeting all required academic courses while simultaneously earning electives credits focused on the Circus Arts. AICE students are also able to participate in the Circus Arts Program.
- Students are required to incorporate cross-curricular skills through a journaling, research, and presentations throughout their participation in the Circus Arts program.
- Circus Arts Program students develop not only their bodies but their minds as resilient, focused, cooperative, and integrated young adults.



Diploma Options

DIPLOMA OPTION	ELIGIBLE CANDIDATES
<p align="center">STANDARD DIPLOMA and 24 CREDIT EARLY GRADUATION</p>	<p>Students who have earned the state/district-prescribed credits, meet the state/district GPA requirement, and earn passing scores as defined by the State of Florida on the required graduation assessments. Note: These guidelines are subject to change during the school year based on state legislative changes. Students may graduate prior to the 8th semester if all graduation requirements are met and 24 credits are earned.</p>
<p align="center">STANDARD DIPLOMA WITH SAT/ACT CONCORDANT SCORES</p>	<p>•Students who have met all course work, credits, and GPA graduation requirements (set forth by the state and local school board) and use an ACT or SAT score concordant with passing scores to satisfy the assessment graduation requirements. Note: These guidelines are subject to change during the school year based on state legislative changes.</p>
<p align="center">STANDARD DIPLOMA WITH WAIVER</p>	<ul style="list-style-type: none"> •ESE students who have completed all necessary credits, course work, and GPA requirements for graduation as stipulated by the local School Board and State of Florida. •Students who have demonstrated knowledge, skills and abilities required by the Grade 10 State Standards but unable to document that mastery through the actual assessment. •Students who have participated in the required remediation activities offered through the school district. •Students who have taken the assessments at least twice, including once in Grade 10 and once in Grade 11. •This diploma option is for students who have been identified as having a disability and a current Individual Education Plan (IEP). •The IEP Committee must convene and review all data relevant to each student's eligibility for the waiver. <p>Note: The above guidelines are subject to change during the school year based on state legislative changes.</p>
<p align="center">CERTIFICATE OF COMPLETION PERT ELIGIBLE</p>	<ul style="list-style-type: none"> •Students who have completed all required credits, course work, and GPA requirements for graduation as stipulated by the local School Board and state. •Students who have not achieved the required scores on the required graduation assessments nor obtained State of Florida defined concordant scores.
<p align="center">CERTIFICATE OF COMPLETION</p>	<p>Students who have met all course requirements and earned the required credits but have not passed the required assessments or have not met the required GPA for graduation.</p>
<p align="center">ACCESS DIPLOMA</p>	<p>Students entering 9th grade for the first time in 2014-15 must be enrolled in general education core courses unless the IEP team has determined that the student has a significant cognitive disability and that access points are the most appropriate way for the student to access the curriculum. Students receiving instruction in access points and taking the alternate assessment should be enrolled in access courses. Access courses are based on access points, are approved by the State Board of Education and are described in the Course Code Directory (CCD) and Instructional Personnel Assignments, in accordance with Rule 6A-1.09441, F.A.C. Students taking access courses must have written parental consent on record to be provided instruction in the state standards access points curriculum, as required by Rule 6A-6.0331, F.A.C.</p>
<p align="center">STANDARD DIPLOMA ACCEL PROGRAM 18 CREDIT</p>	<p>Students who earn the required 15 core requirements for a standard diploma (HOPE is not required, virtual course is not required); pass required assessments and earn 3 elective credits; 2.0 minimum unweighted GPA.</p>
<p align="center">CTE GRADUATION PATHWAY OPTION</p>	<p>Beginning with the 2019-2020 school year, a student may earn a standard high school diploma through the Career and Technical Education (CTE) pathway option. For more details, please visit: http://www.fldoe.org/academics/career-adult-edu/career-tech-edu/pathways-option.html Note: These guidelines are subject to change during the school year based on state legislative changes.</p>

Course Legend:

Max Credits 1.0 .5 U-Unlimited

The maximum number of credits a student can earn for the given course.

Wghtd Y-Weighted N-Not Weighted

FAS/FMS C-Core N-Not Core

Course can be used to meet Florida Academic Scholars and Florida Medallion Scholars 15 academic core requirements.

IB C-Advanced Placement N-No E-Elective (**note: Sarasota High School does not offer IB courses**)

4YR/GSV C-Core N-Not core

Course can be used to meet Florida Gold Seal Vocational Scholars award 15.5 high school graduation core requirements

(for students choosing the 24-credit graduation option).

CTE Y-Yes N-No

Course is part of a career-technical program.

SUS Admissn. E-Elective C-Core N-Not Used P-Pending

Course applicable toward State University System admissions.

SAMPLE

Max Credits	Wghtd	FAS/FMS	IB	4YR/GSV	CTE	SUS/Admissn
1.00	N	C	N	C	Y	C

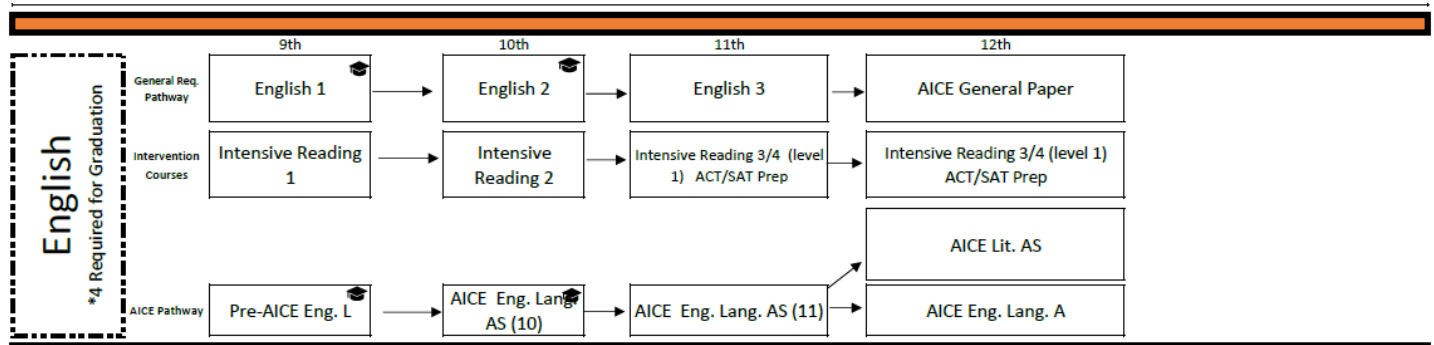

Note: Students who have not earned passing scores (as defined by the State of Florida) on the FAST reading AND/OR scores on other assessments that are required by the State of Florida will be co-enrolled in Intensive Reading.

ENGLISH 1

Grades 9-12

1001310

Max Credits	Wghtd	FAS/FMS	IB	4 YR/GSV	CTE	SUS Admissn
1.00	N	C	N	C	N	C

Prerequisite(s): None

This course provides instruction in English language skills including reading, writing, speaking, vocabulary, and listening in the content areas of literature and language. Students read and analyze short stories, drama, and essays. Composition focuses on the writing process, particularly essay construction. The study of language includes usage, mechanics, spelling, and other elements of standard written English.

PRE-AICE ENGLISH LANGUAGE

Grades 9

1001560

Max Credits	Wghtd	FAS/FMS	IB	4 YR/GSV	CTE	SUS Admissn
1.00	Y	C	N	C	N	C

Prerequisite(s): Teacher Recommendation

Cambridge IGCSE First Language English is designed for learners whose first language is English. Cambridge IGCSE First Language English learners develop the ability to communicate clearly, accurately, and effectively in both speech and writing. They learn how to employ a wide-ranging vocabulary, use correct grammar, spelling, and punctuation, and develop a personal style and an awareness of the audience being addressed. Learners are also encouraged to read widely, both for their own enjoyment and to further their awareness of the ways in which English can be used. Cambridge IGCSE First Language English also develops more general analysis and communication skills such as synthesis, inference, and the ability to order facts and present opinions effectively.

ENGLISH 2**Grades 9-12****1001340**

Max Credits	Wghtd	FAS/FMS	IB	4 YR/GSV	CTE	SUS Admissn
1.00	N	C	N	C	N	C

Prerequisite(s): English 1 or Pre-AICE English Language

This course includes instruction in reading and vocabulary necessary for comprehension of printed materials. Composition instruction focuses on the writing of essays for various purposes and audiences, using literary and non-literary subjects. The study of mass media includes an analysis of propaganda and persuasion techniques. Speech instruction includes analysis of effective techniques in oral presentations. The study of language includes usage, mechanics, spelling, and other elements of standard written English.

AICE ENGLISH GENERAL PAPER 1**Grades 12****1009400**

Max Credits	Wghtd	FAS/FMS	IB	4 YR/GSV	CTE	SUS Admissn
1.00	Y	C	N	C	N	C

Prerequisite(s): English 1 or Pre-AICE English Language and Teacher Recommendation

This course is a multi-disciplinary curriculum. It encourages students to make cross-curricular links; to develop a language which enables them to express arguments, ideas, and opinions in a reflective and academic manner

ENGLISH 3**Grades 9-12****1001370**

Max Credits	Wghtd	FAS/FMS	IB	4 YR/GSV	CTE	SUS Admissn
1.00	N	C	N	C	N	C

Prerequisite(s): English 2

This course includes composition instruction with frequent practice in writing, multiple-paragraph essays in a variety of types, including literary analysis and a brief documented paper Literature study includes the analysis of various examples of literary works. The emphasis should be on the works of American authors; however, literature representative of other cultures may be used to support integrated studies and multicultural emphasis. Vocabulary study focuses on verbal analogies and other patterns commonly found on standardized tests.

AICE ENGLISH LANGUAGE AS LEVEL**Grades 11-12****1001550****AICE ENGLISH LANGUAGE A LEVEL****Grades 12****1001551**

Max Credits	Wgtd	FAS/FMS	IB	4 YR/GSV	CTE	SUS Admissn
1.00	Y	C	N	C	N	C

Prerequisite(s): Teacher Recommendation

Cambridge International AS and A Level English Language gives learners the opportunity to study English language and its use in contemporary communication. It aims to encourage a critical response to texts in a range of forms, styles and contexts, and to promote skills of communication, reading, research and analysis. Through their study, learners will develop an ability to read and analyze material, gaining further knowledge and understanding of English language features and issues, and writing clearly, accurately, creatively, and effectively for different purposes and audiences.

ENGLISH 4 HONORS**Grades 12****1001410**

Max Credits	Wgtd	FAS/FMS	IB	4 YR/GSV	CTE	SUS Admissn
1.00	Y	C	N	C	N	C

Prerequisite(s): English 3

The purpose of this course is to provide grade 12 students, using texts of high complexity, integrated language arts study in reading, writing, speaking, listening, and language for college and career preparation and readiness. **Students who completed AICE General Paper as a 10th grade student, will be enrolled on English 4 Honors in place of AICE General paper in grade 12.**

AICE ENGLISH LITERATURE 1 AS LEVEL**Grades 12****1005370**

Max Credits	Wgtd	FAS/FMS	IB	4 YR/GSV	CTE	SUS Admissn
1.00	Y	C	N	N	N	C

Prerequisite(s): Teacher Recommendation

Learners following the Cambridge International AS Level English syllabus will study a range of texts in the three main forms: prose, poetry, and drama. Set texts are offered from a wide range of different periods and cultures. Learners will develop skills of reading and analysis of texts and are encouraged to undertake wider reading to aid understanding of the texts studied. They will learn skills of effective and appropriate communication including the ability to discuss the critical context of texts.

ENGLISH 1 THROUGH ESOL**Grades 9-12****1002300**

Max Credits	Wghtd	FAS/FMS	IB	4 YR/GSV	CTE	SUS Admissn
1.00	N	C	N	C	N	C

Prerequisite(s): Identification as an ELL Student

The course requirements are consistent with English I, course number 1001340. The instructor shall provide appropriate instructional strategies to meet the needs of ESOL students enrolled in this course. Students earning credit in English I Through ESOL may not earn credit in English Skills I, English I, or English Honors I.

ENGLISH 2 THROUGH ESOL**Grades 9-12****1002310**

Max Credits	Wghtd	FAS/FMS	IB	4 YR/GSV	CTE	SUS Admissn
1.00	N	C	N	C	N	C

Prerequisite(s): Identification as an ELL Student and English 1

The requirements for this course are consistent with English II, course number 1001320. The instructor shall provide appropriate instructional strategies to meet the needs of ESOL students enrolled in this course. Students earning credit in English II Through ESOL may not earn credit in English Skills II, English II, or English Honors II.

ENGLISH 3 THROUGH ESOL**Grades 9-12****1002320**

Max Credits	Wghtd	FAS/FMS	IB	4 YR/GSV	CTE	SUS Admissn
1.00	N	C	N	C	N	C

Prerequisite(s): Identification as an ELL Student and English 2

The requirements for this course are consistent with English III, course number 1001370. The teacher shall provide appropriate instructional strategies to meet the needs of ESOL students enrolled in this course. Students earning credit in English III Through ESOL may not earn credit in English Skills III, English III, or English Honors III. The emphasis is on the works of American authors; however, literature representative of other cultures may be used to support integrated studies and multicultural emphases

ENGLISH 4 THROUGH ESOL**Grades 9-12****1002520**

Max Credits	Wghtd	FAS/FMS	IB	4 YR/GSV	CTE	SUS Admissn
1.00	N	C	N	C	N	C

Prerequisite(s): Identification as an ELL Student and English 3

The requirements for this course are consistent with English IV, course number 1001400. The teacher shall provide appropriate instructional strategies to meet the needs of ESOL student enrolled in this course. Students earning credit in English IV Through ESOL may not earn credit in English Skills IV, English IV, or English Honors IV. The emphasis may be on the works of British authors; however, literature representative of other cultures may be used to support integrated studies and multicultural emphases.

ENGLISH LANGUAGE ARTS ELECTIVES

ENGLISH LANGUAGE DEVELOPMENT

Grades 9-12

1002380

DEVELOPMENTAL LANGUAGE ARTS (Reading)

Grades 9-12

1002381

Max Credits	Wghtd	FAS/FMS	IB	4 YR/GSV	CTE	SUS Admissn
1.00	N	N	N	N	N	C

Prerequisite(s): Limited English Proficiency-Non-Speakers (NES) and Limited English Speakers

The purpose of this course is to enable students who are native speakers of languages other than English to develop proficient listening, speaking, reading, and writing skills in the English language. Emphasis will be on acquisition of integrated English communication skills in a wide range of activities and content areas. The content should include, but not be limited to the following: vocabulary for formal and informal conversation; reading and writing skills; integrated communication skills for school and work; participation in communicative tools to reflect the connection between oral and written language; practice using skills and strategies in order to support the process of language acquisition and the learning of concepts; exposure to and practice in applying academic language; practice applying study skills and learning strategies in all subject areas to accomplish meaningful tasks.

INTENSIVE READING 1-4

Grades 9-12

1000400

Max Credits	Wghtd	FAS/FMS	IB	4 YR/GSV	CTE	SUS Admissn
1.00	N	N	N	N	N	E

Prerequisite(s): Students will be placed by State of Florida requirements.

This course is designed as an intervention for students scoring Level 1 or 2 on FAST Reading Exam. Content of the course will be based on a diagnosis of each student's needs for instruction. Students will be given opportunities to develop and apply reading, vocabulary, and writing skills through guided, shared, and independent reading. Instruction in test-taking skills, including performance tasks and comprehension strategies for reading content-area texts, will be emphasized. This course code can be repeated multiple times.

ENGLISH LANGUAGE ARTS ELECTIVES

CREATIVE WRITING 1

Grades 9-12

1009320

Max Credits	Wghtd	FAS/FMS	IB	4 YR/GSV	CTE	SUS Admissn
0.50	N	N	N	N	N	N

Prerequisite(s): None

The purpose of these courses is to enable students to develop and use grade 9-12 writing and language skills for creative expression in a variety of literary forms. Studying and modeling a variety of genres will be emphasized at this level of creative writing.

DEBATE 1	Grades 9-12	1007330
DEBATE 2	Grades 9-12	1007340
DEBATE 3 HONORS	Grades 9-12	1007350
DEBATE 4 HONORS	Grades 9-12	1007360

Max Credits	Wghtd	FAS/FMS	IB	4 YR/GSV	CTE	SUS Admissn
1.00	N (1-2) / Y (3-4)	N	N	N	N	E

Prerequisite(s): Previous Courses in progression and Teacher Recommendation

These courses provide instruction in the fundamentals of formal and informal oral communication. Major instructional areas include forms of oral communication, techniques of group discussion, techniques of effective listening, analysis of the audience, and techniques of public speaking. These courses enable students to develop and practice skills and techniques for use in debate and forensic activities. **Please note: Debate 3 and 4 are weighted for honors credit.**

AICE MEDIA STUDIES AS LEVEL	Grades 10-12	1100460
------------------------------------	---------------------	----------------

Max Credits	Wghtd	FAS/FMS	IB	4 YR/GSV	CTE	SUS Admissn
1.00	Y	N	N	E	N	E

Prerequisite(s): Teacher Recommendation

Cambridge International AS and A Level Media Studies offers learners the chance to develop an understanding and appreciation of the place of media in our everyday lives. The syllabus enables learners to take a hands-on approach to the subject. Through the coursework components - the Foundation Portfolio for AS Level and the Advanced Portfolio for A Level - they create their own media products from planning through to execution. Learners also consider and analyze examples from existing media, examining production processes and technologies and the effects they achieve.

AICE THINKING SKILLS AS LEVEL	Grades 10-12	1700372
--------------------------------------	---------------------	----------------

AICE THINKING SKILLS A LEVEL	Grades 10-12	1700374
-------------------------------------	---------------------	----------------

Max Credits	Wghtd	FAS/FMS	IB	4 YR/GSV	CTE	SUS Admissn
1.00	Y	N	N	N	N	E

Prerequisite(s): Teacher Recommendation

Thinking Skills is an intriguing course that allows candidates to develop a specific set of transferable skills in Critical Reasoning and Problem Solving. The focus of the Critical Reasoning unit is on development of skill sets to: 1. Evaluate the credibility of evidence (information) to make decisions based on rational, logical reasoning; 2. To analyze and draw appropriate conclusions from scientific data; 3. To unpack arguments, identify flaws and reasoning and present reasoned arguments.

Max Credits	Wghtd	FAS/FMS	IB	4 YR/GSV	CTE	SUS Admissn
0.50	N	N	E	E	N	N

Prerequisite(s): None

Students who participate in this semester-long course for freshmen will begin planning for their post-secondary future and begin mastering the basic skills necessary for college and career success. The purpose of this course is to develop career planning competencies, enabling students to make informed career choices and develop the skills needed to successfully plan and apply for college or a job.

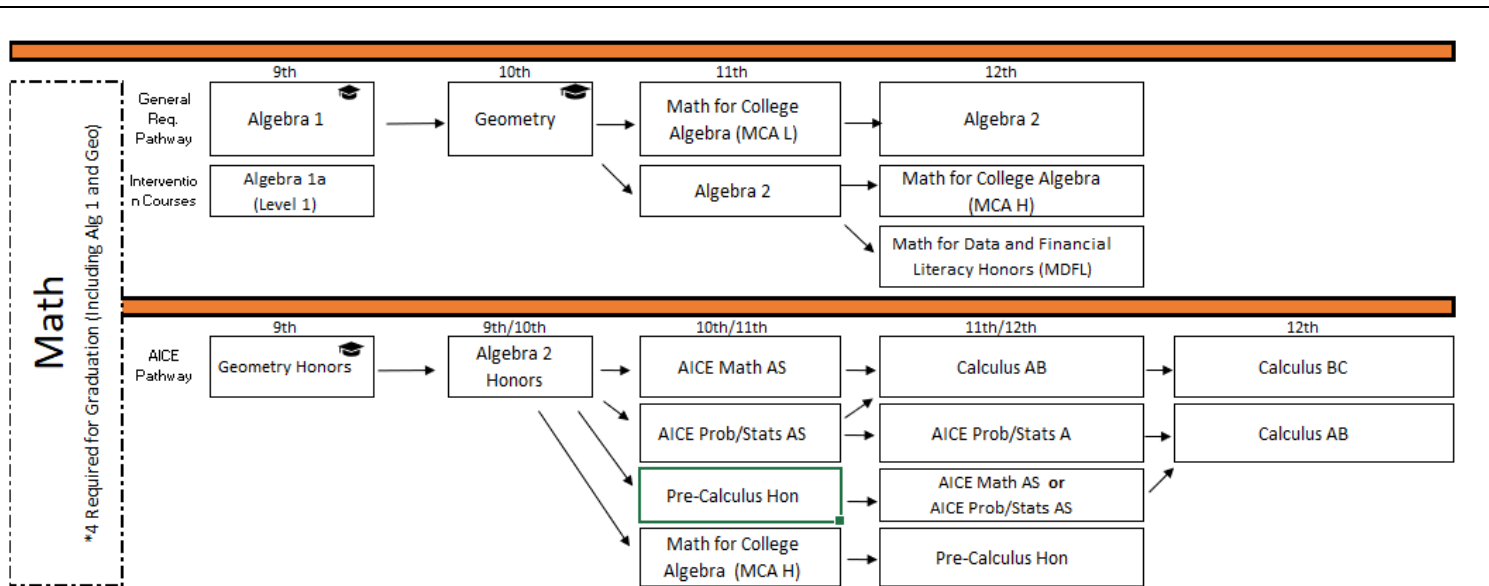

ALGEBRA 1A

Grades 9-12

1200370

Max Credits	Wghtd	FAS/FMS	IB	4 YR/GSV	CTE	SUS Admissn
1.00	N	E	N	E	N	E

Prerequisite(s): None

This course is a study of the topics of Algebra I designed to develop the algebraic concepts and processes that can be used to solve a variety of real-world mathematics problems. ***This course is designed to support the foundations of algebra for students who perform at level 1 math concurrently enrolled in Algebra 1.***

ALGEBRA 1

Grades 9-12

1200310

Max Credits	Wghtd	FAS/FMS	IB	4 YR/GSV	CTE	SUS Admissn
1.00	N	C	N	C	N	C

Prerequisite(s): None

This course is a study of the topics of Algebra I designed to develop the algebraic concepts and processes that can be used to solve a variety of real-world mathematics problems. The content will include: structure and properties of the real number system, varied means for analyzing and expressing patterns, relations and functions; variable, algebraic expressions and polynomials; geometric concepts; data analysis concepts and techniques; and varied solution strategies, algebraic and graphic, solutions for inequalities, linear and quadratic equations, and for systems of equations. Students must take the End-of-Course Exam administered through the State of Florida. Students must PASS the EOC to meet the graduation requirements from the State of Florida.

GEOMETRY**Grades 9-12****1206310**

Max Credits	Wghtd	FAS/FMS	IB	4 YR/GSV	CTE	SUS Admissn
1.00	N	C	N	C	N	C

Prerequisite(s): Algebra 1

The purpose of this course is to develop the geometric relationships and deductive strategies that can be used to solve a variety of real world and mathematical problems. The content will include Euclidean geometry of lines, planes, angles, triangles, construction and logic, and properties of circles, polygons, right triangle trigonometry, and reinforcement of algebraic concepts. Calculators and computers will serve as instructional tools in concept development. Students must take the End-of-Course Exam administered through the State of Florida.

GEOMETRY HONORS**Grades 9-12****1200320**

Max Credits	Wghtd	FAS/FMS	IB	4 YR/GSV	CTE	SUS Admissn
1.00	Y	C	N	C	N	C

Prerequisite(s): Algebra 1 and Teacher Recommendation

This course is designed to give a rigorous in-depth study of geometry with emphasis on methods of proof and the formal language of mathematics. The content will include the following: structure of geometry, separation properties, angle concepts, triangles, quadrilaterals, proofs, perpendicularity, and parallelism in a plane and in space, similar polygons, circles and spheres, constructions, area and volume, coordinate geometry, and topology. Calculators and computers will serve as instructional tools in concept development.

ALGEBRA 2**Grades 9-12****1200330**

Max Credits	Wghtd	FAS/FMS	IB	4 YR/GSV	CTE	SUS Admissn
1.00	N	C	N	C	N	C

Prerequisite(s): Geometry

This course is designed to continue the study of the structure of algebra and to provide the foundation for applying these skills to other mathematical and scientific fields. The content will include structure and properties of the complex number system, sequences and series, relations, functions and graphs, varied solution strategies for linear equations, inequalities, and systems of equations and inequalities, conic sections and their applications, data analysis, reinforcement of geometric concepts, and probability. Calculators and computers will serve as instructional tools in concept development.

ALGEBRA 2 HONORS**Grades 9-12****1200340**

Max Credits	Wghtd	FAS/FMS	IB	4 YR/GSV	CTE	SUS Admissn
1.00	Y	C	N	C	N	C

Prerequisite(s): Geometry Honors and Teacher Recommendation

This course is a rigorous in-depth study of the topics of Algebra II with emphasis on theory, proof, and development of formulas, as well as their application. The content will include structure and properties of the complex number system, sequences and series, relations, functions and graphs, varied solution strategies for linear equations, inequalities, and systems of equations and inequalities, conic sections and their applications, data analysis, and probability. Calculators and computers will serve as instructional tools in concept development.

MATH FOR COLLEGE ALGBRA**Grades 9-12****1200710**

Max Credits	Wghtd	FAS/FMS	IB	4 YR/GSV	CTE	SUS Admissn
1.00	N	C	N	C	N	C

Prerequisite(s): Algebra 2 and/or Teacher Recommendation

This course is intended to support students who are college bound in a mathematics pathway. The purpose of this course is to ensure students are successful in post-secondary mathematics courses and to avoid placement in the non-credit bearing math remediation course. Students must have algebra 1 and 2 skills to be successful. The standards for this course are an extension of algebra 1 and algebra 2 skills that a student needs to be successful in their post-secondary mathematics courses.

MATH FOR DATA AND FINANCIAL LITERACY HONORS**Grades 9-12****1200384**

Max Credits	Wghtd	FAS/FMS	IB	4 YR/GSV	CTE	SUS Admissn
1.00	Y	C	N	C	N	C

Prerequisite(s): Geometry and Teacher Recommendation

This course is for all students. Note it is “replacing” Financial Algebra but keeping the same course code. The purpose of this course is for students to learn mathematical skills that will ensure success in their future. Some algebra 1 and 2 standards are included, but most standards involve spreadsheets, income tax, interest, currencies, budget skills, credit scores, retirement plans, etc. This course may conflict with Personal Finance.

PRE-CALCULUS Hon**Grades 9-12****1202340**

Max Credits	Wghtd	FAS/FMS	IB	4 YR/GSV	CTE	SUS Admissn
1.00	Y	C	N	C	N	C

Prerequisite(s): Algebra 2 Honors and Teacher Recommendation

The study of trigonometric and circular functions and their applications will be covered in this course. Topics include trigonometric identities, graphs of trigonometric functions, inverses, equations, and solutions of triangles. Stresses relationships among topics of algebra, geometry, and trigonometry and uses these relationships in preparation for calculus. Topics include graphs, curve sketching, vectors, the conic sections, including translation and rotation of axes, equations, and graphs of curves on polar form, analytic proofs, and parametric equations.

AICE MATH 1**Grades 10-12****1202352**

Max Credits	Wghtd	FAS/FMS	IB	4 YR/GSV	CTE	SUS Admissn
1.00	Y	C	N	C	N	C

Prerequisite(s): Algebra 2 Honors and Teacher Recommendation

This course is a comprehensive, rigorous study of advanced pure math. Areas of study include advanced algebra, trigonometry, and calculus. Students in this course are expected to participate in two AICE final papers. College credit is earned with a passing score on these papers. Twelve grade students need to have a qualifying EOC, ACT, or SAT score to take this course.

AICE MATH, PROBABILITY, AND STATISTICS AS LEVEL**Grades 10-12****1202362****AICE MATH, PROBABILITY, AND STATISTICS A LEVEL****Grades 10-12****1202364**

Max Credits	Wghtd	FAS/FMS	IB	4 YR/GSV	CTE	SUS Admissn
1.00	Y	C	N	C	N	C

Prerequisite(s): Algebra 2 Honors and Teacher Recommendation; previous Course in progression

In this course, students develop their mathematical knowledge and skills in a way which encourages confidence and provides satisfaction and enjoyment develop an understanding of mathematical principles and an appreciation of mathematics as a logical and coherent subject. Students will additionally acquire a range of mathematical skills, particularly those which will enable them to use applications of mathematics in the context of everyday situations and of other subjects they may be studying, and develop the ability to analyze problems logically, recognize when and how a situation may be represented mathematically, identify, and interpret relevant factors and, where necessary, select an appropriate mathematical method to solve the problem. Students in this course are expected to participate in two AICE final papers. College credit is earned with a passing score on these papers.

AP CALCULUS AB**Grades 9-12****1202310**

Max Credits	Wghtd	FAS/FMS	IB	4 YR/GSV	CTE	SUS Admissn
1.00	Y	C	C	C	N	C

Prerequisite(s): Pre-Calculus or AICE Math 1 or AICE Math and Probability and Statistics 1 and Teacher Recommendation

This course is designed to offer students college-level mathematics under the guidelines of the Advanced Placement Program. The focus is on preparation for the Calculus Level AB Test given by the College Examination Board in May. Study will begin by reviewing function definitions, absolute value, and elementary functions from prerequisites. Calculators and computers will serve as instructional tools in concept development.

AP CALCULUS BC**Grades 9-12****1202320**

Max Credits	Wghtd	FAS/FMS	IB	4 YR/GSV	CTE	SUS Admissn
1.00	Y	C	C	C	N	C

Prerequisite(s): AP Calculus AB and Teacher Recommendation

This course is designed to offer students college-level mathematics under the guidelines of the Advanced Placement Program. The focus is on preparation for the Calculus Level BC Test given by the College Examination Board in May. Study will begin by reviewing function definitions, concepts of limits to functions, and derivatives of algebraic, trigonometric, exponential, and logarithmic functions. Calculators and computers will serve as instructional tools in concept development.

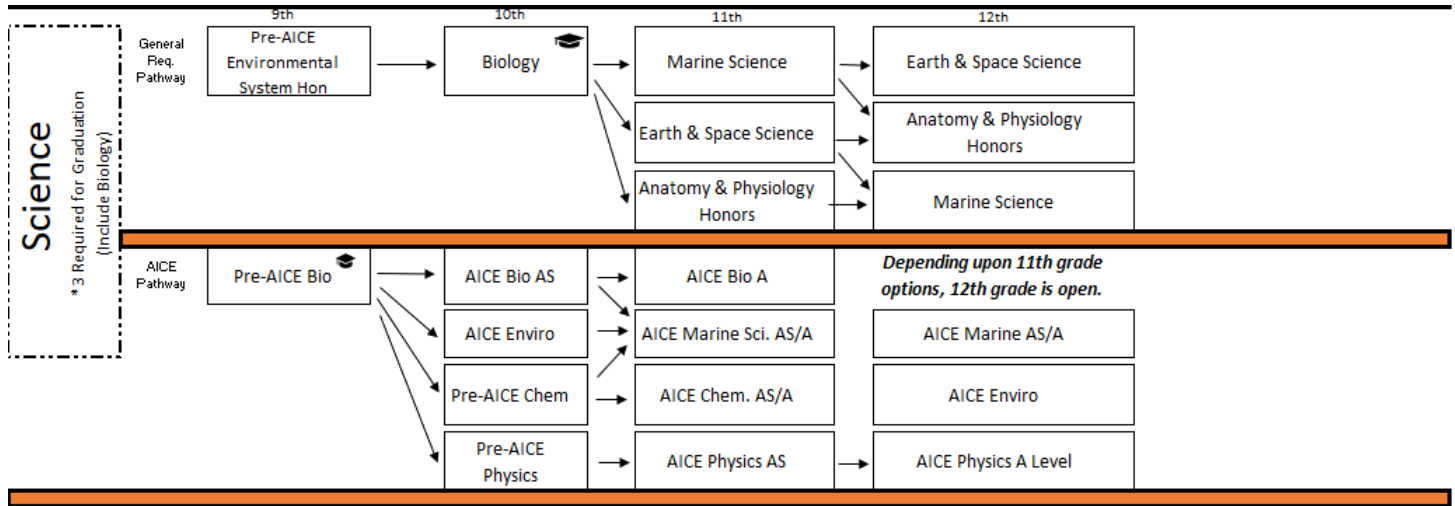

PRE-AICE ENVIRONMENTAL MANAGEMENT

Grades 9-12

2001342

Max Credits	Wghtd	FAS/FMS	IB	4 YR/GSV	CTE	SUS Admissn
1.00	Y	C	N	C	N	C

Prerequisite(s): None

This course provides a study of environmental issues and their management, especially the human aspect. Through their studies, students will learn about environmental resources and their human exploitation, and about the goal of sustainable environmental management. Students also consider a range of case study material which can feature local, regional, or global examples.

BIOLOGY

Grades 9-12

2000310

Max Credits	Wghtd	FAS/FMS	IB	4 YR/GSV	CTE	SUS Admissn
1.00	N	C	N	C	N	C

Prerequisite(s): None

This course provides students with exploratory activities, laboratory experiences and real-life applications in the biological sciences. The content includes the following concepts: nature of science, matter, energy, chemical processes of life, reproduction and communication of cells, basic study of genetics, organization, classification and taxonomy, structure, reproduction and function of plants, animals, and microorganisms, interdependence of living things, adaptations, and the impact of technology on society. Preserved animal studies may be a part of this course. Students must take the End-of-Course Exam (EOC) administered through the State of Florida. The Biology EOC will count as 30% of students' final grade in the course.

PRE-AICE BIOLOGY**Grades 9-12****2000322**

Max Credits	Wghtd	FAS/FMS	IB	4 YR/GSV	CTE	SUS Admissn
1.00	Y	C	N	C	N	C

Prerequisite(s): Teacher Recommendation

This advanced course provides integrated laboratory experiences and real-life applications in the essential processes of life. The content includes the nature of science, matter, energy, biochemistry, cell biology, genetics, levels of organization and classification, structure, function and reproduction of plants, animals, and microorganisms, behavior of organisms, interrelationships among organisms, biological selection, adaptations and changes through time. Laboratory investigations will include the use of the scientific method, measurement, observations, predictions, reasoning and problem-solving skills. Preserved animal studies may be a part of this course. Students must take the End-of-Course Exam (EOC) administered through the State of Florida. The Biology EOC will count as 30% of students' final grade in the course.

AICE BIOLOGY AS LEVEL**Grades 10-12****2000321****AICE BIOLOGY A LEVEL****Grades 10-12****2000323**

Max Credits	Wghtd	FAS/FMS	IB	4 YR/GSV	CTE	SUS Admissn
1.00	Y	C	N	C	N	C

Prerequisite(s): Pre-AICE Biology and previous course in progression and Teacher Recommendation

Practical skills are assessed in a timetabled practical examination. The emphasis throughout is on the understanding of concepts and the application of biology ideas in novel contexts as well as on the acquisition of knowledge. The course encourages creative thinking and problem-solving skills which are transferable to any future career path.

AGRISCIENCE FOUNDATIONS 1**Grades 9-12****8106810**

Max Credits	Wghtd	FAS/FMS	IB	4 YR/GSV	CTE	SUS Admissn
1.00	Y	C	N	C	N	C

Prerequisite(s): None

This course is designed to develop competencies in the areas of agricultural history and the global impact of agriculture; career opportunities; scientific and research concepts; biological and physical science principles; environmental principles; agriscience safety; principles of leadership; and agribusiness, employability, and human relations skills in agriscience. Laboratory-based activities are an integral part of this course. These include the safe use and application of appropriate technology, scientific testing and observation equipment.

ANATOMY AND PHYSIOLOGY HONORS**Grades 9-12****2000360**

Max Credits	Wghtd	FAS/FMS	IB	4 YR/GSV	CTE	SUS Admissn
1.00	Y	C	N	C	N	C

Prerequisite(s): Biology and Teacher Recommendation

This advanced course provides exploratory activities in the structure and function of the components of the human body. The content includes anatomical terminology, cellular biology, histology, homeostasis, immune response, organization and interrelatedness of major body systems, sensory function, and human disorders. Laboratory investigations focus on the use of the scientific method, measurement, laboratory apparatus, and safety. Preserved animal studies may be a part of the laboratory experience.

PRE-AICE CHEMISTRY**Grades 9-12****2003372**

Max Credits	Wghtd	FAS/FMS	IB	4 YR/GSV	CTE	SUS Admissn
1.00	Y	C	N	C	N	C

Prerequisite(s): Algebra 1, Biology, and Teacher Recommendation

This advanced course involves the study of the composition, properties and changes of matter, atomic structure, the periodic table, bonding, gas laws, energy and order, reaction rates and equilibrium, solutions, nuclear, electric, and organic chemistry. Selected laboratory activities include the use of the scientific method, measurement, laboratory apparatus, and safety.

AICE CHEMISTRY 1 AS LEVEL**Grades 10-12****2003371****AICE CHEMISTRY 1 A LEVEL****Grades 10-12****2003373**

Max Credits	Wghtd	FAS/FMS	IB	4 YR/GSV	CTE	SUS Admissn
1.00	Y	C	N	C	N	C

Prerequisite(s): Pre-AICE Chemistry and Teacher Recommendation

Practical skills are assessed in a timetabled practical examination. The emphasis throughout is on the understanding of concepts and the application of chemistry ideas in novel contexts as well as on the acquisition of knowledge. The course encourages creative thinking and problem-solving skills which are transferable to any future career path. Completion of Pre AICE Chemistry or AICE Biology AND Algebra II with a grade of a B or better is required.

PRE-AICE PHYSICS**Grades 9-12****2003432**

Max Credits	Wghtd	FAS/FMS	IB	4 YR/GSV	CTE	SUS Admissn
1.00	Y	C	N	C	N	C

Prerequisite(s): Algebra II or Algebra II Honors and Teacher Recommendation

This advanced course provides a rigorous study of the concepts, theories and laws governing the interaction of matter, energy, and the forces of nature. The content includes kinematics, dynamics, energy, work and power, heat and thermodynamics, waves, light, electricity, magnetism, nuclear physics, and sound. Laboratory investigations of selected topics include the use of the scientific method, measurement, laboratory apparatus, and safety.

AICE PHYSICS 1 AS LEVEL**Grades 10-12****2003431****AICE PHYSICS 2 A LEVEL****Grades 10-12****2003433**

Max Credits	Wghtd	FAS/FMS	IB	4 YR/GSV	CTE	SUS Admissn
1.00	Y	C	N	C	N	C

Prerequisite(s): Pre-AICE Physics and previous course in progression and Teacher Recommendation

Cambridge International AS and A Level Physics builds on the skills acquired at Cambridge IGCSE (or equivalent) level. The syllabus includes the main theoretical concepts which are fundamental to the subject, a section on some current applications of physics, and a strong emphasis on advanced practical skills. Practical skills are assessed in a timetabled practical examination. The emphasis throughout is on the understanding of concepts and the application of physics ideas in novel contexts as well as on the acquisition of knowledge. The course encourages creative thinking and problem-solving skills which are transferable to any future career path. Cambridge International AS and A Level Physics is ideal for learners who want to study physics or a wide variety of related subjects at university or to follow a career in science

MARINE SCIENCE 1**Grades 9-12****2002500**

Max Credits	Wghtd	FAS/FMS	IB	4 YR/GSV	CTE	SUS Admissn
1.00	N	C	N	C	N	C

Prerequisite(s): Algebra 1 and Biology or Pre-AICE Biology

This course provides an overview of the marine environment. The content may include the nature of science, the origins of oceans, the chemical, physical and geological aspects of the ecology of various sea zones, marine communities, the diversity of marine organisms, characteristics of major marine ecosystems, characteristics of major phyla/divisions, & the interrelationship between man and the ocean.

AICE MARINE SCIENCE 1 AS LEVEL**Grades 10-12****2002515****AICE MARINE SCIENCE 2 A LEVEL****Grades 10-12****2002535**

Max Credits	Wghtd	FAS/FMS	IB	4 YR/GSV	CTE	SUS Admissn
1.00	Y	C	N	C	N	C

Prerequisite(s): Algebra 1, Biology or Pre-AICE Biology, previous course in progression, and Teacher Recommendation

These advanced courses provide an in-depth study of the physical, chemical, and biological aspects of the marine environment. The content includes the origins of the oceans, marine geological studies, ecology of the sea zones, diversity of marine organisms, characteristics of the major marine ecosystems including the phyla and divisions, and the interrelationship between man and the ocean. Laboratory investigations will include the use of the scientific method, measurement, laboratory apparatus and safety procedures. Preserved specimens may be a part of this course. **Please note: these courses must be taken as a double block.**

AICE ENVIRONMENTAL MANAGEMENT AS LEVEL Grades 10-12**2001381**

Max Credits	Wghtd	FAS/FMS	IB	4 YR/GSV	CTE	SUS Admissn
1.00	Y	C	N	C	N	C

Prerequisite(s): Algebra 1 and Biology or Pre-AICE Biology and Teacher Recommendation

Environmental management is concerned with both local and global issues and with the various ways in which societies, governments, and economic activity (industry, agriculture, and urban areas) use, misuse and attempt to manage both local and global environments. Whilst environmental management can often be presented in a negative light by emphasizing pollution, exploitation, and misuse, it is important to give recognition to the positive ways in which we manage our environment. Thus, issues such as global warming, industrial pollution and the impact of rapid population growth need to be balanced with others like the creation of National Parks, sensitive urban design and sustainable management/development.

MaST SCIENCE ELECTIVES (REQUIRED FOR MaST STUDENTS)

EXPERIMENTAL SCIENCE 1 HONORS	Grades 9-12	2002340
EXPERIMENTAL SCIENCE 2 HONORS	Grades 9-12	2002350
EXPERIMENTAL SCIENCE 3 HONORS	Grades 9-12	2002360
EXPERIMENTAL SCIENCE 4 HONORS	Grades 9-12	2002370
AP CAPSTONE SEMINAR	Grades 10-12	1700500
AP CAPSTONE RESEARCH	Grades 10-12	1700510

Max Credits	Wghtd	FAS/FMS	IB	4 YR/GSV	CTE	SUS Admissn
1.00	Y	C	N	C	N	C

Prerequisite(s): Acceptance into the MaST Program, previous courses in progression, and Teacher Recommendation

These courses are designed to teach students about the scientific process and help them to use sound scientific practices in real world situations. Our courses use the scientific method to conduct various experiments and tests in the field of electrical, mechanical and computer engineering. We will be working with our hands and learning new skills to design and implement our designs in class. Our learning will be practical, and project based. **Please note: These courses do not meet the high school graduation science credit requirement. Please see MaST program progression for more details.**

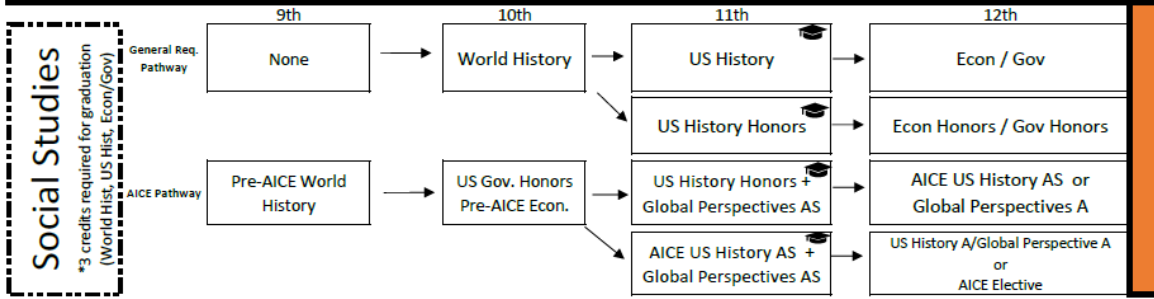

WORLD HISTORY

Grades 9-12

2109310

Max Credits	Wghtd	FAS/FMS	IB	4 YR/GSV	CTE	SUS Admissn
1.00	N	C	N	C	N	C

Prerequisite(s): None

The purpose of this course is to enable students to understand their connections to the development of civilizations by examining the past to prepare for their future as participating members of a global community. Students will use knowledge pertaining to history, geography, economics, political processes, religion, ethics, diverse cultures, and humanities to solve problems in academic, civic, social and employment settings.

PRE-AICE WORLD HISTORY

Grades 9-12

2109321

Max Credits	Wghtd	FAS/FMS	IB	4 YR/GSV	CTE	SUS Admissn
1.00	Y	C	N	C	N	C

Prerequisite(s): Teacher Recommendation

The purpose of this course is to promote the acquisition of knowledge and understanding of human activity in the past, promote an understanding of the nature of cause and consequence, continuity and change, similarity, and difference, and to encourage international understanding. A placement AICE paper will be administered at the end of this course along with teacher recommendations to determine course selection for grade 10.

U.S. HISTORY**Grades 9-12****2100310**

Max Credits	Wghtd	FAS/FMS	IB	4 YR/GSV	CTE	SUS Admissn
1.00	N	C	N	C	N	C

Prerequisite(s): None

The purpose of this course is to enable students to understand the development of the United States within the context of history with a major focus on the post-Reconstruction period. Student will use knowledge pertaining to history, geography, economics, political processes, religion, ethics, diverse cultures, and humanities to solve problems in academic, civic, social, and employment settings. Students must take the End-of-Course Exam administered through the State of Florida. Students must take the End-of-Course Exam (EOC) administered through the State of Florida. The U.S. History EOC will count as 30% of students' final grade in the course.

U.S. HISTORY HONORS**Grades 9-12****2100320**

Max Credits	Wghtd	FAS/FMS	IB	4 YR/GSV	CTE	SUS Admissn
1.00	Y	C	N	E	N	C

Prerequisite(s): Teacher Recommendation

The purpose of this course is to enable students to understand the development of the United States within the context of history with a major focus on the post-Reconstruction period. Students will use knowledge pertaining to history, geography, economics, political processes, religion, ethics, diverse cultures, and humanities to solve problems in academic, civic, social, and employment settings. Students must take the End-of-Course Exam administered through the State of Florida. Students must take the End-of-Course Exam (EOC) administered through the State of Florida. The U.S. History EOC will count as 30% of students' final grade in the course.

AICE U.S. HISTORY AS LEVEL**Grades 11-12****2100500****AICE U.S. HISTORY A LEVEL****Grades 12****2100505**

Max Credits	Wghtd	FAS/FMS	IB	4 YR/GSV	CTE	SUS Admissn
1.00	Y	C	N	E	N	C

Prerequisite(s): Teacher Recommendation and previous course in progression

The purpose of these courses is to enable students to understand the development of the United States within the context of history with a major focus on the post-Reconstruction period. Student will use knowledge pertaining to history, geography, economics, political processes, religion, ethics, diverse cultures, and humanities to solve problems in academic, civic, social, and employment settings.

AMERICAN GOVERNMENT**Grades 9-12****2106310**

Max Credits	Wghtd	FAS/FMS	IB	4 YR/GSV	CTE	SUS Admissn
0.50	N	C	N	C	N	C

Prerequisite(s): None

The purpose of this course is to enable students to gain an understanding of American government and political behavior that is essential for effective citizenship and active involvement in a democratic American society.

AMERICAN GOVERNMENT HONORS**Grades 9-12****2106320**

Max Credits	Wghtd	FAS/FMS	IB	4 YR/GSV	CTE	SUS Admissn
0.50	Y	C	N	C	N	C

Prerequisite(s): Teacher Recommendation

The purpose of this course is to enable students to gain an understanding of American government and political behavior that is essential for effective citizenship and active involvement in a democratic American society. Honors/Advanced courses offer scaffolded learning opportunities for students to develop the critical skills of analysis, synthesis, and evaluation in a more rigorous and reflective academic setting.

PRE-AICE ECONOMICS**Grades 9-12****2102323**

Max Credits	Wghtd	FAS/FMS	IB	4 YR/GSV	CTE	SUS Admissn
0.50	Y	C	N	C	N	C

Prerequisite(s): Teacher Recommendation

The Cambridge IGCSE Economics syllabus develops an understanding of economic theory, terminology, and principles. Learners study the economics of different countries and how these interrelate. They also learn to work with simple economics data and to use the tools of economic analysis. Learners apply understanding of economics to current economic issues.

ECONOMICS**Grades 9-12****2102310**

Max Credits	Wghtd	FAS/FMS	IB	4 YR/GSV	CTE	SUS Admissn
0.50	N	C	N	C	N	C

Prerequisite(s): None

The purpose of this course is to the study of the concepts and processes of the national and international economic systems. Students use knowledge pertaining to the fundamental concepts relevant to the major economic systems, the global market and economy, major economic theories, the role and influence of the government and fiscal policies, economic measurements, tools, and methodology, financial and investment markets, and the business cycle.

ECONOMICS HONORS**Grades 9-12****2102320**

Max Credits	Wghtd	FAS/FMS	IB	4 YR/GSV	CTE	SUS Admissn
0.50	Y	C	N	C	N	C

Prerequisite(s): Teacher Recommendation

The purpose of this course is to provide opportunities for students to develop the critical skills of analysis, synthesis, and evaluation in a more rigorous and reflective academic setting. Students will use knowledge pertaining to the study of concepts and process of the national and international economic systems.

PSYCHOLOGY 1**Grades 9-12****2107300**

Max Credits	Wghtd	FAS/FMS	IB	4 YR/GSV	CTE	SUS Admissn
0.50	N	C	N	E	N	C

Prerequisite(s): Previous course in progression

The purpose of these courses is to provide students an understanding of human behavior, behavioral interaction, and the progressive development of individuals. Students will acquire an understanding of and an appreciation for human behavior, behavior interaction and the progressive development of individuals. This will better prepare them to understand their own behavior and the behavior of others. Content will include the theories and methods of study employed by psychologists, human growth and development, self-concept development, adjustment, memory, personality and behavior, emotion and frustration, abnormal behavior, conformity, autonomy, alienation, stress, mental health, and therapy.

AICE PSYCHOLOGY AS LEVEL**Grades 10-12****2107360****AICE PSYCHOLOGY A LEVEL****Grades 11-12****2107370**

Max Credits	Wghtd	FAS/FMS	IB	4 YR/GSV	CTE	SUS Admissn
1.00	Y	C	N	E	N	C

Prerequisite(s): None

Cambridge International AS Level Psychology learners develop their appreciation of the subject by exploring the ways in which psychology is conducted. As part of their studies, learners also review important research; this provides an insight into the ways in which psychology has been applied, thereby leading to a better understanding of key themes and issues. The syllabus reflects the five core areas of psychology, namely cognitive, social, physiological, and developmental and the psychology of individual differences; it also relates psychology to education, health, organizations, the environment, and abnormality

AICE GLOBAL PERSPECTIVES AS LEVEL**Grades 11-12****1700364****AICE GLOBAL PERSPECTIVES A LEVEL****Grade 12****1700365**

Max Credits	Wghtd	FAS/FMS	IB	4 YR/GSV	CTE	SUS Admissn
1.00	Y	C	N	E	N	C

Prerequisite(s): Teacher Recommendation and previous course in progression

Global Perspectives is a course that is cross-curricular, stretching across traditional subject boundaries. It taps into the way students of today enjoy learning as well as including group work, seminars, projects, and working with other students around the world. The emphasis is on developing the ability to think critically about a range of global issues where there is always more than one point of view. **Please note: AICE Global Perspectives is a required course in grade 11 for AICE students.**

LAW STUDIES**Grades 9-12****2106350**

Max Credits	Wghtd	FAS/FMS	IB	4 YR/GSV	CTE	SUS Admissn
0.50	N	C	N	E	N	C

Prerequisite(s): None

The grade 9-12 Law Studies course consists of the following content area strands: American History, World History, Geography, Humanities, Economics, and Civics and Government. The primary content for the course pertains to the study of the American legal system as the foundation of American society by examining those laws which have an impact on citizens' lives and an introduction to fundamental civil and criminal justice procedures. Content should include, but is not limited to, the need for law, the basis for our legal system, civil and criminal law, adult and juvenile courts, family and consumer law, causes and consequences of crime, individual rights and responsibilities, and career opportunities in the legal system.

AICE SOCIOLOGY 1 AS LEVEL**Grades 10-12****2108310**

Max Credits	Wghtd	FAS/FMS	IB	4 YR/GSV	CTE	SUS Admissn
1.00	Y	C	N	E	N	C

Prerequisite(s): Teacher recommendation, Previous course in progression

In a rapidly changing world, Cambridge International AS and A Level Sociology offers students the opportunity not only to explore the processes that are shaping current trends, but also to develop an understanding of the complexity and diversity of human societies and their continuities with the past. The study of Sociology should stimulate awareness of contemporary social, cultural, and political issues, and focus attention on the importance of examining these issues in a rigorous, reasoned and analytical way. The Cambridge International AS Level provides a solid grounding in the central ideas and approaches in Sociology, including family as well as theory and methods. Cambridge International A Level students can choose to explore a variety of important areas of sociological enquiry including global development, education, religion and media.

PERSONAL FINANCE AND MONEY MANAGEMENT**Grades 9-12****2102371**

Max Credits	Wghtd	FAS/FMS	IB	4 YR/GSV	CTE	SUS Admissn
0.50	Y/N	C	N	E	N	C

Prerequisite(s): None

The primary content for the course pertains to the study of learning the ideas, concepts, knowledge and skills that will enable students to implement beneficial personal decision-making choices; to become wise, successful, and knowledgeable consumers, savers, investors, users of credit and money managers; and to be participating members of a global workforce and society. ***Please note: This course is a graduation requirement for cohort 2027 and beyond.***

AICE TRAVEL AND TOURISM AS LEVEL**Grades 10-12****2102410**

Max Credits	Wghtd	FAS/FMS	IB	4 YR/GSV	CTE	SUS Admissn
1.00	Y	N	E	C	N	E

Prerequisite(s): Teacher recommendation

Travel and Tourism is designed to help meet the need for skilled and knowledgeable individuals in this rapidly diversifying industry. The intention of the syllabus is to provide a broad introduction to the travel and tourism industry and related ancillary service industries. The syllabus develops practical skills across a range of working roles, as well as providing a global and local perspective on travel and tourism. Students gain an overview of the industry, and learn about popular destinations, customer care, working procedures, travel and tourism products and services, and marketing and promotion. Through their studies, students will gain an understanding of the concepts, models and theories used within the industry, and also enhance their skills of investigation, analysis, interpretation and evaluation.

WORLD LANGUAGES**SPANISH 1****Grades 9-12****0708340**

Max Credits	Wghtd	FAS/FMS	IB	4 YR/GSV	CTE	SUS Admissn
1.00	N	C	N	E	N	C

Prerequisite(s): No Prerequisite

The purpose of this course is to introduce students to the target language and its culture and to develop communicative skills and cross-cultural understanding. The content includes beginning skills in listening and speaking with special attention to pronunciation. An introduction to reading and writing is included, as well as the fundamentals of grammar and culture.

SPANISH 2**Grades 9-12****0708350**

Max Credits	Wghtd	FAS/FMS	IB	4 YR/GSV	CTE	SUS Admissn
1.00	N	C	N	E	N	C

Prerequisite(s): Spanish I

The purpose of this course is to reinforce the fundamental skills acquired previously by the students. This course develops increased listening, speaking, reading, and writing skills as well as cultural awareness. The content includes an expansion of listening and oral skills. Reading and writing receive more emphasis, while oral communication remains the primary objective. This course continues the cultural survey of Spanish-speaking people.

PRE-AICE SPANISH 1**Grades 9-12****0708532****PRE-AICE SPANISH 2****Grades 9-12****0708534****PRE-AICE SPANISH 3****Grades 9-12****0708536****AICE SPANISH 1 AS LEVEL****Grades 10-12****0708538****AICE SPANISH 1 LANG AND LIT A LEVEL****Grades 11-12****0708550**

Max Credits	Wghtd	FAS/FMS	IB	4 YR/GSV	CTE	SUS Admissn
1.00	Y	C	N	E	N	C

Prerequisite(s): Teacher Recommendation and previous course in progression

This syllabus is designed for learners who are learning Spanish as a foreign language. The aim is to develop an ability to use the language effectively for practical communication. These courses are based on the linked language skills of listening, reading, speaking and writing, and these are built on as the learner progresses through their studies. The courses also aim to offer insights into the culture and civilization of countries where the language is spoken, thus encouraging positive attitudes towards language learning and towards speakers of foreign languages.

AMERICAN SIGN LANGUAGE 1

Grades 9-12

0717300

AMERICAN SIGN LANGUAGE 2

Grades 9-12

0717310

Max Credits	Wgtd	FAS/FMS	IB	4 YR/GSV	CTE	SUS Admissn
1.00	N / Y	C	N	E	N	C

Prerequisite(s): Previous course in progression

This course enables students to begin to acquire proficiency in American Sign language through a linguistic, communicative, and cultural approach to language learning. Emphasis is place on the development of receptive and expressive signing skill and on the acquisition of the fundamentals of applied grammar. Cross-cultural understanding is fostered, and real-life applications are emphasized throughout the course.

CAREER AND TECHNICAL EDUCATION (CTE)



CTEX
CAREER AND TECHNICAL EDUCATION



Sarasota High School
2025-2026

Exercise Science 8417000	Culinary Arts 8800500	Applied Engineering Technology 8401100	Multimedia Visual Design 8201600	Multimedia Video Design 8201600	Plant & Animal Applications 8129200	Aquaculture 8004100	Business Ownership 8812000	Work-based Learning
Certified Medical Administrative Assistant (CMAA)	Certified Food Protection Manager (ServSafe) Certified Food Safety Manager	Autodesk Certified User: Inventor, AutoCAD, Revit, Fusion 360, SolidWorks, RC(Pre-Eng & Robotics)	Adobe Photoshop AND Illustrator OR InDesign Adobe Premiere Pro AND Photoshop, OR After Effects, Word Press	Adobe Photoshop AND Illustrator OR InDesign Adobe Premiere Pro AND Photoshop, OR After Effects, Word Press	Agriculture Associate Certified Food Protection Manager (ServSafe)	Agriculture Associate Aquaculture Technician	Entrepreneurship & Small Business	*No Specific Order *All course prerequisites must be fulfilled including completion of CTE Pathway *Students should be in 11th or 12 grade
Health Science Anatomy & Physiology * 8417100	Culinary Arts 1 8800510	Applied Engineering Technology 1 8401130	Multimedia Foundations 1 (Visual/Video) 8201210	Multimedia Foundations 1 (Visual/Video) 8201210	Agriculture Foundations 1 8129210	Marine Science 2002300 OR	Business Ownership 8812000	Coop Diversified Education OIT 8300430 OR
Health Science Foundations * 8417140	Culinary Arts 2 8800530	Applied Engineering Technology 2 8401130	Multimedia Foundations 2 (Visual) 8201230	Multimedia Foundations 3 (Video) 8201230	Food Science Applications 2 8129230	Agriculture Foundations 1 8129210	Work Experience 1 8301610 AND	Work Experience 1 8301610 AND
Exercise Science * 8417130	Culinary Arts 3 8800530	Applied Engineering Technology 3 8401130	Multimedia Web Production (Visual) 8201610	Multimedia Motion Graphics Production (Video) 8201620	Food Science Applications 3 8129230	Aquaculture 2 8112020	Work Experience OIT 8301650 OR	Work Experience OIT 8301650 OR
	Culinary Arts 4 8800540, 8800550 8800560	Advanced Technology Applications 8601900				Aquaculture 3 8112030	Career and Technical Education Internship 8300930 OR	Diversified Education Directed Study 8300100
						Aquaculture 4 8112030		

CTE Course meets the Practical Arts graduation requirement
 = Level 3 course (0.5 Honors weight)
 *Course meets the online graduation requirement
 EQ= equally rigorous science
 MA= Course meets mathematics graduation requirements
 Underlined certifications Statewide college articulation and may substitute for up to two math credits
 (except for Algebra 1 and Geometry) or substitute for up to one science credit (except for Biology 1)

BUSINESS OWNERSHIP**Grades 9-12****8812000**

Max Credits	Wghtd	FAS/FMS	IB	4 YR/GSV	CTE	SUS Admissn
1.00	Y	N	E	C	Y	E

Prerequisite(s): None

The purpose of this program is to prepare students for careers as entrepreneurs, present entrepreneurship as a career path worthy of consideration, provide students with the skills needed to realistically evaluate their potential as business owners, and develop the fundamental knowledge and skills necessary to start and operate a business.

DIGITAL MEDIA/MULTIMEDIA FOUNDATIONS 1	GRADE 9-12	8201210
DIGITAL M/M FOUNDATIONS 2 (Web/Visual)	GRADE 10-12	8201220
DIGITAL M/M FOUNDATIONS 3 (Video)	GRADE 10-12	8201230
DIGITAL MEDIA/MULTIMEDIA WEB PRODUCTION	GRADE 11-12	8201610
DIGITAL MEDIA/MULTIMEDIA MOTION GRAPHICS	GRADE 11-12	8201620

Max Credits	Wghtd	FAS/FMS	IB	4 YR/GSV	CTE	SUS Admissn
1.00	N / Y	N	E	C	Y	E

Prerequisite(s): Previous course in progression with teacher recommendation

These courses continue the development of basic entry-level skills required for careers in the digital publishing industry. The content includes computer skills; digital publishing operations; layout, design, and measurement activities; decision-making activities, and digital imaging. Students can choose visual or video pathway after Foundations 1.

APPLIED ENGINEERING 1 HONORS	Grades 9-12	8401110
APPLIED ENGINEERING 2 HONORS	Grades 9-12	8401120
APPLIED ENGINEERING 3 HONORS	Grades 9-12	8401130

Max Credits	Wghtd	FAS/FMS	IB	4 YR/GSV	CTE	SUS Admissn
1.00	Y	N	E	C	Y	E

Prerequisite(s): Previous course in progression with teacher recommendation

These courses help students understand the field of engineering/ engineering technology. Exploring various technology systems and manufacturing processes help students learn how engineers and technicians use math, science and technology in an engineering problem solving process to benefit people. The courses also include concerns about social and political consequences of technological change.

ADVANCED TECHNOLOGY APPLICATIONS HONORS**Grades 9-12****8601900**

Max Credits	Wghtd	FAS/FMS	IB	4 YR/GSV	CTE	SUS Admissn
1.00	Y	N	E	C	Y	E

Prerequisite(s): Applied Engineering 3 and previous courses in progression with teacher recommendation

This is the fourth course in the engineering program. Students continue to prepare for postsecondary engineering programs by developing a more in-depth master of the required knowledge and skills in mathematics, science, and technology.

HEALTH SCIENCE ANATOMY**Grades 9-12****8417100****HEALTH SCIENCE FOUNDATIONS****Grades 9-12****8417110****EXERCISE SCIENCE****Grades 9-12****8417120**

Max Credits	Wghtd	FAS/FMS	IB	4 YR/GSV	CTE	SUS Admissn
1.00	Y	N	E	C	Y	E

Prerequisite(s): Previous course in progression with teacher recommendation

The purpose of these courses is to prepare students for employment as health aides, nurse aides, orderlies or health service aides. Content will emphasize knowledge of anatomy and physiology, medical terminology, and representative skills of health care workers. The courses will emphasize an integration of scientific principles based on anatomy or physiology, attendant medical terminology, disease control, condition of illness and common therapy, and introduction to clinical learning experiences.

CULINARY 1**Grades 9-12****8800510****CULINARY 2****Grades 9-12****8800520****CULINARY 3****Grades 9-12****8800530****CULINARY 4****Grades 9-12****8800540**

Max Credits	Wghtd	FAS/FMS	IB	4 YR/GSV	CTE	SUS Admissn
1.00	Y/N	N	E	C	Y	E

Prerequisite(s): Previous course in progression

The purpose of these courses is to provide students with competencies basic to a cluster of occupations in the food service industry and to develop skills, knowledge, and attitude for success and advancement in a specialized occupational proficiency program. Course content includes employability skills, qualifications, and career opportunities; introduction to operational procedures; characteristics and functions of types of food service establishments; safety, sanitation, security, and storage procedures; identifications, use, care, and storage of commercial tools and equipment; cooking terms and vocabulary; standard and metric measurements; food preparation; and rules and regulations governing the food industry.

FOOD SCIENCE APPLICATIONS 2**Grades 9-12****8129210****FOOD SCIENCE APPLICATIONS 3****Grades 9-12****8129220**

Max Credits	Wghtd	FAS/FMS	IB	4 YR/GSV	CTE	SUS Admissn
1.00	Y	N	E	C	Y	E

Prerequisite(s): Agriscience Foundations 1

This course is designed to develop competencies in the concepts related to: the use of taste and other sensory tests in developing foods; the application of scientific principles in food processing; food marketing; nutritional and economic value of plant-based food products; safe and efficient distribution and handling of food products; environmental factors in food production and processing; the global and historical impact of food on people; and employability skills necessary in the food industry.

Aquaculture 2**Grades 9-12****8112010****Aquaculture 3****Grades 9-12****8112020****Aquaculture 4****Grades 9-12****8112030**

Max Credits	Wghtd	FAS/FMS	IB	4 YR/GSV	CTE	SUS Admissn
1.00	Y	N	E	C	Y	E

Prerequisite(s): Agriscience Foundations 1 or Marine Science

This program offers a sequence of courses that provides coherent and rigorous content aligned with challenging academic standards and relevant technical knowledge and skills needed to prepare for further education and careers in the Agriculture, Food and Natural Resources career cluster; provides technical skill proficiency, and includes competency-based applied learning that contributes to the academic knowledge, higher-order reasoning and problem-solving skills, work attitudes, general employability skills, technical skills, and occupation-specific skills, and knowledge of all aspects of the Agriculture, Food and Natural Resources career cluster.

The content includes but is not limited to instruction in the planning, management, finance, technical and production skills, underlying principles of technology, labor issues, community issues and health, safety and environmental issues in the aquaculture industry.

WORK BASED LEARNING OPPORTUNITIES

ON THE JOB TRAINING (OJT)

COOPERATIVE DIVERSIFIED ED

Grades 11-12

8301650

Max Credits	Wghtd	FAS/FMS	IB	4 YR/GSV	CTE	SUS Admissn
Varies	N	N	E	C	N	N

Prerequisite(s): Completion of courses in a CTE Program with teacher recommendation/approval

These courses provide on-the-job training for students enrolled in Career and Technical Education programs. This course is an extension of the school's classroom setting in which learning experiences are provided to prepare students for employment CTE occupations / career cluster.

EXECUTIVE INTERNSHIP

EXECUTIVE INTERNSHIP 1

Grades 12

0500300

EXECUTIVE INTERNSHIP 2

Grades 12

0500310

EXECUTIVE INTERNSHIP 3

Grades 12

0500320

Max Credits	Wghtd	FAS/FMS	IB	4 YR/GSV	CTE	SUS Admissn
Varies	N	N	N	E	N	N

Prerequisite(s): Must have a 3.0 and teacher approval *See counselor for more information

The purpose of this course is to provide a practical introduction to the work environment through direct contact with professionals in the community. The content should include, but not be limited to, the following: discussion of professional job requirements, awareness, and knowledge of career opportunities, building vocabulary appropriate to the area of professional interest, development of decision-making skills, development of personal and educational job-related skills.

JROTC

ARMY: LEADERSHIP EDUCATION AND TRAINING 1	Grades 9-12	0801300
ARMY: LEADERSHIP EDUCATION AND TRAINING 2	Grades 9-12	0801310
ARMY: LEADERSHIP EDUCATION AND TRAINING 3	Grades 9-12	0801320
ARMY: LEADERSHIP EDUCATION AND TRAINING 4	Grades 9-12	0801330

Max Credits	Wghtd	FAS/FMS	IB	4 YR/GSV	CTE	SUS Admissn
1.00	N	N	E	E	N	E

Prerequisite(s): None for Level I, Prior level for II/IV

The purpose of these courses is to enable students to develop knowledge of the history, customs, traditions, and purpose of the Army JROTC. The courses include development of basic leadership skills including leadership principles, values, and attributes. Students should master appreciation for diversity. Active learning strategies are integrated throughout the course with an emphasis on writing skills and oral communication techniques. Financial planning as well as physical fitness, diet nutrition, healthy lifestyles, awareness of substance abuse and prevention, and basic first aid measures are included. An overview of the globe and geography and basic map reading skills are incorporated. A study of the United States Constitution, Bill of Rights, responsibilities of United States citizens, and the federal justice system is also provided. Level II expands the content of Level I. **Please note: Two successful years of JROTC can provide students their required HOPE credit.**

Raider Team: Cadets gain skills in camping, kayaking, backpacking, rappelling, orienteering and wilderness survival. Rangers participate in competitive tasks, physical fitness, high and low rope courses, water safety training and S.E.A.L. training. This team is very physically demanding.

Drill Team and Color Guard: Cadets learn regular and exhibition precision drills with and without rifles. Cadets also participate in color guards at parades, football games and community service events. Additionally, cadets compete in county, district, and state competitions.

Rifle Marksmanship: Cadets learn Basic Rifle Marksmanship and compete with .177 CO2 powered pellet rifles. Competitive meets are also held between JROTC units throughout the county, the state, and through US Postal Matches.

JLAB (JROTC Leadership and Academic Bowl): is an all-service national competition that culminates in the Level III JLAB Championship in Washington DC. Teams demonstrate knowledge on SAT/ACT questions as well as JROTC Leadership curriculum. There are three levels of competition among schools nationwide ending in the top 40 teams competing head-to-head during Level III. Students increase their ability to take college entrance exams and learn teamwork skills.

VISUAL ARTS

VISUAL ART COURSES

General Art Courses – Fine Art Graduation Requirement is 1 credit



- Ceramics I (1 cr.)
- 3D Studio Art 1 (1 cr.)
- 2D Studio Art 1 (1 cr.)
- Creative Photo 1 (1 cr.)
- Visual Tech/Animation 1 (1 cr.)
- Fine Crafts 1 (1 cr.)

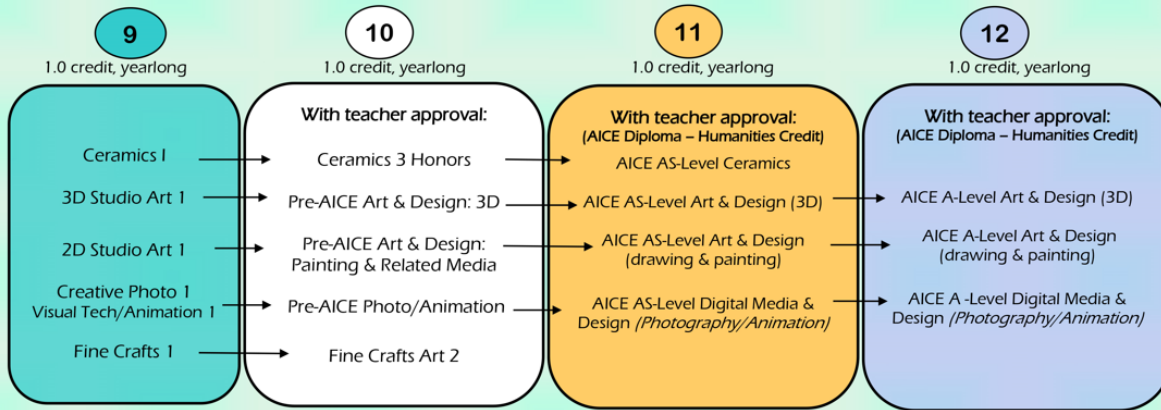

2-D STUDIO ART 1 (DRAWING & PAINTING)

Grades 9-12

0101300

Max Credits	Wgtd	FAS/FMS	IB	4 YR/GSV	CTE	SUS Admissn
1.00	N	N	N	C	N	E

Prerequisite(s): None

The Elements of Art are used to emphasize observational drawing, painting, mixed media, and vocabulary which include technical skill building. Composition is explored using the Principles of Design through a variety of materials. **Sketchbook and Sharpies are required.**

3-D STUDIO ART 1 (SCULPTURE)

Grades 9-12

0101330

Max Credits	Wgtd	FAS/FMS	IB	4 YR/GSV	CTE	SUS Admissn
1.00	N	N	N	C	N	E

Prerequisite(s): None

These courses enable students to communicate ideas or concepts using three-dimensional design and composition. Students explore the elements of art and principles of design through the creation of a variety of functional and sculptural objects, and using different media.

CERAMICS/POTTERY 1**Grades 9-12****0102300****CERAMICS/POTTERY 3 HONORS****Grades 9-12****0102320**

Max Credits	Wghtd	FAS/FMS	IB	4 YR/GSV	CTE	SUS Admissn
1.00	Y/N	N	N	C	N	E

Prerequisite(s): None

This course enables students to communicate ideas or concepts using three-dimensional design and composition. Processes and techniques may include, but are not limited to, hand-built clay and surface decorations. Students explore the elements of art and principles of design through the creation of a variety of functional and sculptural objects. Comp II students refine use of vocabulary, techniques and learn how to wheel-thrown clay. Content will make cultural and historical connections. **Sketchbook required.**

FINE CRAFT ART STUDIO 1**Grades 9-12****0101440****FINE CRAFT ART STUDIO 2****Grades 10-12****0101450**

Max Credits	Wghtd	FAS/FMS	IB	4 YR/GSV	CTE	SUS Admissn
1.00	N	N	N	C	N	E

Prerequisite(s): None

Students develop the language of fine craft through a concentration on fundamental technical skills using a variety of materials. Student artisans reflect on aesthetics and visual issues related to fine craft using the structural elements of art and organizational principles of design. **Sketchbook and Sharpies are required.**

CREATIVE PHOTOGRAPHY 1**Grades 9-12****0108310**

Max Credits	Wghtd	FAS/FMS	IB	4 YR/GSV	CTE	SUS Admissn
1.00	N	N	N	C	N	E

Prerequisite(s): None

Students explore the aesthetic foundations of art making using beginning photography techniques. This course may include, but are not limited to, color and/or black and white photography via digital media. Students become familiar with the basic mechanics of a camera, including lens and shutter operation, compositional foundations, printing an image for display, and evaluating a successful print. Student photographers may use a variety of media and materials, single lens reflex camera, digital camera, computer application, filters, various papers, digital output, cyanotypes, and Sabatier effect. Craftsmanship and quality are reflected in the surface of the prints and the care of the materials. Photographers use an art criticism process to evaluate, explain, and measure artistic growth in personal or group works. This course incorporates hands-on activities and consumption of art materials.

VISUAL TECHNOLOGY 1 (ANIMATION)**Grades 9-12****0107440**

Max Credits	Wghtd	FAS/FMS	IB	4 YR/GSV	CTE	SUS Admissn
1.00	N	N	N	C	N	E

Prerequisite(s): None

Students explore the fundamental concepts, terminology, techniques, and applications for creating ANIMATION. Students produce flipbooks, claymations, and animated digital images through the single or combined use of computers, digital cameras, digital video cameras, scanners, photo editing software, drawing, and painting software, and graphic tablets. Through the critique process, students evaluate and respond to their own work and that of their peers to measure artistic growth.

PRE-AICE PHOTOGRAPHY (PHOTOGRAPHY/ANIMATION)**Grades 9-12****0108355**

Max Credits	Wghtd	FAS/FMS	IB	4 YR/GSV	CTE	SUS Admissn
1.00	Y	N	N	C	N	E

Prerequisite(s): Teacher Recommendation

Students will create a portfolio and display of various photography and animation techniques. They may work in multiple methods. The student will need to be able to explain their inspiration and accurately discuss major art movements.

PRE-AICE ART AND DESIGN: DRAWING AND PAINTING**Grades 9-12****0104415**

Max Credits	Wghtd	FAS/FMS	IB	4 YR/GSV	CTE	SUS Admissn
1.00	Y	N	N	C	N	E

Prerequisite(s): Teacher Recommendation

Students will be introduced to the AICE Art process and creating artwork. They may work in multiple methods. The student will need to be able to explain their inspiration and accurately discuss major art movements. **Sketchbook and Sharpie pens are required.**

PRE-AICE ART AND DESIGN: 3D STUDIES (CERAMICS/SCULPTURE)**Grades 9-12****0101375**

Max Credits	Wghtd	FAS/FMS	IB	4 YR/GSV	CTE	SUS Admissn
1.00	Y	N	N	C	N	E

Prerequisite(s): Teacher Recommendation

Students will create a portfolio and display of various artwork. They will work in multiple media methods. The student will need to be able to explain their inspiration and accurately discuss major art movements. **Sketchbook and Sharpie pens are required.**

AICE ART AND DESIGN 1 AS LEVEL**Grades 10-12****0101370****AICE ART AND DESIGN 2 A LEVEL****Grades 10-12****0101371**

Max Credits	Wghtd	FAS/FMS	IB	4 YR/GSV	CTE	SUS Admissn
1.00	Y	N	N	C	N	E

Prerequisite(s): Teacher Recommendation and previous course for A Level

Cambridge Art and Design has been designed to offer a broad choice of media and approaches so that students can produce a personal response which can play to their strengths in terms of expertise and interests. Students will create a portfolio and display of artwork. They may work in multiple methods. The student will need to be able to explain their inspiration and accurately discuss major art movements. **Please note: These course codes are used for both the 2D Studio Art and 3D Studio Art progression.**

AICE DIGITAL MEDIA AND DESIGN AS LEVEL**Grades 10-12****0108400****AICE DIGITAL MEDIA AND DESIGN A LEVEL****Grades 10-12****0108410**

Max Credits	Wghtd	FAS/FMS	IB	4 YR/GSV	CTE	SUS Admissn
1.00	Y	N	N	C	N	E

Prerequisite(s): Teacher Recommendation and previous course for A Level

Cambridge Art and Design has been designed to offer a broad choice of media and approaches so that students can produce a personal response which can play to their strengths in terms of expertise and interests. Students will create a photo and/or animation portfolio and display of artwork. They may work in multiple methods. The student will need to be able to explain their inspiration and accurately discuss major art movements.

AICE ART AND DESIGN CERAMICS 1 AS LEVEL**Grades 10-12****0102330**

Max Credits	Wghtd	FAS/FMS	IB	4 YR/GSV	CTE	SUS Admissn
1.00	Y	N	N	C	N	E

Prerequisite(s): Teacher Recommendation and previous course in progression

Cambridge Art and Design has been designed to offer a broad choice of media and approaches so that students can produce a personal response which can play to their strengths in terms of expertise and interests. Students will create a portfolio and display of artwork. They may work in multiple methods. The student will need to be able to explain their inspiration and accurately discuss major art movements. Sketchbook Required

PERFORMING ARTS

General Information for Band Students

Placement in a band class is determined by the instructor. Students enrolling in instrumental courses **MUST** have an appropriate instrument to participate in class activities. The school provides a limited number of basic instruments for use by students upon receipt of a donation fee for the school year, payable in the Fall. Students using these instruments are responsible for their care and safety at all times. All band students are required to obtain appropriate black shoes and black socks. \$25.00 donation requested for band uniform rental. The money donated is used for maintenance and replacement of the uniforms. Financial assistance can be obtained for students from the Band Director. The following ensembles are performance oriented. Performances and rehearsals outside of the regular school day are **REQUIRED**.

BAND 3	Grades 9-12	1302320
BAND 4	Grades 10-12	1302330
BAND 5 HONORS	Grades 11-12	1302340
BAND 6 HONORS	Grades 11-12	1302350

Max Credits	Wghtd	FAS/FMS	IB	4 YR/GSV	CTE	SUS Admissn
1.00	N	N	N	C	N	E

Prerequisite(s): Band 2, 3, and 4 - previous course or Teacher Recommendation

The purpose of these courses is to enable students to develop technical skills on wind or percussion instruments through the refinement and performance of high school band literature. Emphasis will be placed on the development of skills in interpretation of notation and expressive markings, individual and ensemble performance, and critical listening. Content will include technical skills, individual and ensemble techniques, music literacy, sight reading and ear training. Students will analyze performances, and understand and apply skills in improvisation, composition, and arranging. Students will understand the elements and characteristics of music, and the role and influence of instrumental music and musicians. They will explore connections between music and other subject areas and demonstrate responsible participation in music activities. These courses require students to participate in extra rehearsals and performances beyond the school day.

JAZZ ENSEMBLE 1	Grades 9-12	1302500
JAZZ ENSEMBLE 2	Grades 9-12	1302510
JAZZ ENSEMBLE 3	Grades 9-12	1302520
JAZZ ENSEMBLE 4 HONORS	Grades 9-12	1302530

Max Credits	Wghtd	FAS/FMS	IB	4 YR/GSV	CTE	SUS Admissn
1.00	N / Y	N	N	C	N	E

Prerequisite(s): Jazz Ensemble 2, 3, and 4 - previous course or Teacher Recommendation

The purpose of these courses is to enable students to develop skills in jazz performance through knowledge of styles and performance techniques of varied jazz and contemporary literature. Content includes technical skills, individual and ensemble techniques, performance styles, and jazz idioms, rhythms, and articulation. Improvisation skills are emphasized. Students will compose and arrange as well as analyze literature, and their own and others' performances. Students will study history and the role and influence of jazz, and contemporary music and musicians. Students will understand connections between music and other subject areas, as well as responsible participation in music activities. This course requires students to participate in extra rehearsals and performances beyond the school day. **Please note: Jazz Ensemble 4 is weighted for honors credit.**

INSTRUMENTAL TECHNIQUES 1	Grades 9-12	1302420
INSTRUMENTAL TECHNIQUES 2	Grades 9-12	1302430
INSTRUMENTAL TECHNIQUES 3	Grades 9-12	1302440
INSTRUMENTAL TECHNIQUES 4 HONORS	Grades 9-12	1302450

Max Credits	Wghtd	FAS/FMS	IB	4 YR/GSV	CTE	SUS Admissn
1.00	N / Y	N	N	C	N	E

Prerequisite(s): Previous experience with playing drums, Instrumental Techniques 2, 3, and 4 - previous course or Teacher Recommendation

Students in this entry-level class focus on the development of musical and technical skills on a percussion through etudes, scales, and selected music literature. Through problem-solving, critical thinking, and reflection, students develop the physical and cognitive skills to be more disciplined performers. Public performances may serve as a culmination of specific instructional goals. Students may be required to attend and/or participate in rehearsals and performances outside the school day to support, extend, and assess learning in the classroom. This course may also require students to obtain a musical instrument (e.g., borrow, rent, purchase) from an outside source. **Please note: Instrumental Techniques 4 is weighted for honors credit.**

INSTRUMENTAL ENSEMBLE 1	Grades 9-12	1302460
INSTRUMENTAL ENSEMBLE 2	Grades 9-12	1302470
INSTRUMENTAL ENSEMBLE 3	Grades 9-12	1302480
INSTRUMENTAL ENSEMBLE 4 HONORS	Grades 9-12	1302490

Max Credits	Wghtd	FAS/FMS	IB	4 YR/GSV	CTE	SUS Admissn
1.00	N / Y	N	N	C	N	E

Prerequisite(s): Instrumental Ensemble 2, 3, and 4 - previous course or Teacher Recommendation

These courses enable students to develop performance skills on a selected instrument in a larger ensemble setting using varied high school literature. Performance techniques, music knowledge, critical analysis, and aesthetic response are emphasized. Content includes technical skills, individual ensemble techniques, music literacy, sight reading and ear training. Students will understand the elements and characteristics of music, improvisation, composition, and arranging. Students will analyze their own and others' performances and understand the role and influence of instrumental music and musicians. Responsible participation in music activities is emphasized. This course requires students to participate in extra rehearsals and performances beyond the school day. **Please note: Instrumental Ensemble 4 is weighted for honors credit.**

GUITAR 1	Grades 9-12	1305300
-----------------	--------------------	----------------

Max Credits	Wghtd	FAS/FMS	IB	4 YR/GSV	CTE	SUS Admissn
1.00	N / Y (Level 4)	N	N	C	N	E

Prerequisite(s): Previous course in progression

The purpose of these courses is to enable students to develop skills in guitar performance, including reading and interpreting music notation and performance in varied styles. Content will include technical performance proficiency, reading music including chord symbols, chord structure, performance styles and improvisation, composition, and arranging. Students will analyze performances and understand the role and influence of guitar music and musicians, and connections between music and other subject areas.

General Information for Orchestra Students

Placement in an orchestra class is determined by the instructor. Students enrolling in instrumental courses must have an appropriate instrument to participate in class activities. The school provides a limited number of basic instruments for use by students upon receipt of a rental fee for the school year, payable in the Fall. Students using these instruments are responsible for their care and safety at all times. The following ensembles are performance oriented. Rehearsals and performances outside of the regular school day are REQUIRED.

ORCHESTRA 3 **Grades 9-12** **1302380**

ORCHESTRA 4 **Grades 10-12** **1302390**

ORCHESTRA 5 HONORS **Grades 11-12** **1302400**

ORCHESTRA 6 HONORS **Grades 11-12** **1302410**

Max Credits	Wghtd	FAS/FMS	IB	4 YR/GSV	CTE	SUS Admissn
1.00	N	N	N	C	N	E

Prerequisite(s): Orchestra 4, 5, and 6 - previous course or Teacher Recommendation

The purpose of these courses is to enable students to develop technical skills on string or other orchestral instruments through the refinement and performance of high school orchestra literature. Emphasis will be placed on the development of skills in interpretation of notation and expressive markings, individual and ensemble performance, and critical listening. Content will include technical skills, individual and ensemble techniques, music literacy, sight reading, and ear training. Responsible participation in music activities is required. This course requires students to participate in extra rehearsals and performances beyond the school day.

KEYBOARDING 1 **Grades 9-12** **1301360**

Max Credits	Wghtd	FAS/FMS	IB	4 YR/GSV	CTE	SUS Admissn
1.00	N	N	N	C	N	E

Prerequisite(s): None

Students build fundamental piano techniques while learning to read music, acquire and apply knowledge of basic music theory, and explore the role of keyboard music in history and culture. Beginning pianists develop skills in analytical listening and explore musical creativity in the form of basic improvisation and basic composition. Public performances may serve as a culmination of specific instructional goals. Students may be required to attend and/or participate in rehearsals and performances outside the school day to support, extend, and assess learning in the classroom.

AP MUSIC THEORY **Grades 9-12** **1300330**

Max Credits	Wghtd	FAS/FMS	IB	4 YR/GSV	CTE	SUS Admissn
1.00	Y	X3	C	C	N	E

Prerequisite(s): Teacher Recommendation

The major component of any college music curriculum is a course introducing the first-year student to musicianship, theory, musical materials, and procedures. Such a course may bear a variety of titles. The student's ability to read and write musical notation is fundamental to such a course.

General Information for Chorus Students

Since all Chorus Classes are performance oriented, students enrolling in a chorus class will be expected to participate in all rehearsals, concerts, and State Solo Ensemble Festivals as well as Florida Vocal Association's District Performance Assessments. Students and parents will be asked to a class contract. All chorus students are required to obtain black dress shoes and black socks (for boys) or black character shoes with a 2-inch heel (for girls). Uniforms will be rented from the school for \$60.00. The rental money is used for maintenance and replacement of the uniforms. Financial Assistance may be obtained for students from the chorus director. The following ensembles are performances oriented. Rehearsals and performances outside of the regular school day are REQUIRED.

CHORUS 3	Grades 9-12	1303320
CHORUS 4	Grades 9-12	1303330
CHORUS 5 Hon	Grades 9-12	1303340

Max Credits	Wghtd	FAS/FMS	IB	4 YR/GSV	CTE	SUS Admissn
1.00	Y/N	N	N	C	N	E

Prerequisite(s): Chorus 3, 4, and 5 - previous course or Teacher Recommendation

These courses are designed for students with little or no choral experience to experienced chorus students and promotes the enjoyment and appreciation of music through performance of a range of choral repertoires from a variety of times and places. Rehearsals focus on the development of critical listening skills; foundational instrumental technique and skills, music literacy, and ensemble skills; and aesthetic musical awareness culminating in periodic public performances.

VOCAL ENSEMBLE 1	Grades 9-12	1303440
VOCAL ENSEMBLE 2	Grades 9-12	1303450
VOCAL ENSEMBLE 3	Grades 9-12	1303460
VOCAL ENSEMBLE 4 Honors	Grades 9-12	1303470

Max Credits	Wghtd	FAS/FMS	IB	4 YR/GSV	CTE	SUS Admissn
1.00	N/Y	N	N	C	N	E

Prerequisite(s): Audition only, Teacher Recommendation.

The purpose of these courses is to enable students to develop basic performance techniques in a small ensemble setting through the study of varied high school choral literature. Emphasis will be placed on healthy and expressive signing, accurate interpretation of notation, and development of critical and aesthetic response to music. Content includes vocal production, choral performance techniques, music literacy, and sight reading and ear training. Students will understand the elements and characteristics of music, improvisation, composition, and arranging. Students will analyze their own and others' performances and understand the role and influence of choral music and musicians. Connections between music and other subject areas will be made. Responsible participation in music activities is emphasized. This course requires students to participate in extra rehearsals and performances beyond the school day.

THEATRE DEPARTMENT

INTRO TO DRAMA	Grades 9-12	0400300
THEATRE 1	Grades 9-12	0400310
THEATRE 2	Grades 10-12	0400320
THEATRE 3 HONORS	Grades 11-12	0400330
THEATRE 4 HONORS	Grades 11-12	0400340

Max Credits	Wghtd	FAS/FMS	IB	4 YR/GSV	CTE	SUS Admissn
1.00	N/Y	N	N	C	N	E

Prerequisite(s): Drama 2, 3, and 4 - previous course or Teacher Recommendation

These courses provide experiences in the study and practice of theatre arts and literature. Students will learn the fundamentals of theatre production which includes scenery construction, costuming, lighting, make-up, and the fundamentals of acting. Content also includes instruction in specific acting techniques and various dramatic presentations emphasizing acting theories, the practice and theory of set design, make-up, lighting, properties, and directing.

TECHNICAL THEATRE DESIGN & PRODUCTION 1	Grades 9-12	0400410
TECHNICAL THEATRE DESIGN & PRODUCTION 2	Grades 9-12	0400420

Max Credits	Wghtd	FAS/FMS	IB	4 YR/GSV	CTE	SUS Admissn
1.00	N	N	N	C	N	E

Prerequisite(s): None

Students focus on developing the basic tools and procedures for creating elements of technical theatre, including costumes, lighting, makeup, properties (props), publicity, scenery, and sound. Technical knowledge of safety procedures and demonstrated safe operation of theatre equipment, tools, and raw materials are central to success in this course. Students explore and learn to analyze dramatic scripts, seeking production solutions through historical, cultural, and geographic research. Students also learn the basics of standard conventions of design presentation and documentation; the organizational structure of theatre production and creative work in a collaborative environment; and the resulting artistic improvement. Public performances may serve as a culmination of specific instructional goals. Students may be required to attend or participate in technical work, rehearsals, and/or performances beyond the school day to support, extend, and assess learning in the classroom.

PHYSICAL EDUCATION

HEALTH OPTIONS THROUGH PHYSICAL EDUCATION (HOPE)

Grades 9-12

3026010

Max Credits	Wghtd	FAS/FMS	IB	4 YR/GSV	CTE	SUS Admissn
1.00	N	N	N	C	N	N

Prerequisite(s): None

The purpose of this course is to develop and enhance healthy behaviors that influence lifestyle choices and student health and fitness. **Please note: HOPE is a required course for graduation.**

PRE-AICE PHYSICAL EDUCATION IGCSE LEVEL

Grades 9-12

3026015

Max Credits	Wghtd	FAS/FMS	IB	4 YR/GSV	CTE	SUS Admissn
1.00	Y	N	N	C	N	N

Prerequisite(s): None

The purpose of this course is to develop and enhance healthy behaviors that influence lifestyle choices and student health and fitness. Candidates will study all of the following topics: Anatomy and physiology; health, fitness, and training; Skill acquisition and psychology; and social, cultural and ethical influences. Candidates will also undertake four different physical activities that make a significant contribution to syllabus aims and objectives, serving as a source of material to facilitate learning. **Please note: this course counts for students to meet their HOPE requirement for graduation.**

TEAM SPORTS 1

Grades 9-12

1503350

TEAM SPORTS 2

Grades 9-12

1503360

VOLLEYBALL 1

Grades 9-12

1505500

VOLLEYBALL 2

Grades 9-12

1505510

Max Credits	Wghtd	FAS/FMS	IB	4 YR/GSV	CTE	SUS Admissn
0.50	N	N	E	C	N	N

Prerequisite(s): None

Students will learn safety practices, skills, techniques, rules and strategies in selected team sports. Health-related components of fitness will be emphasized. The selected team sports may include, but not be limited to team handball, flickerball, gatorball, speedball, field hockey and track and field.

WEIGHT TRAINING 1**Grades 9-12****1501340****WEIGHT TRAINING 2****Grades 9-12****1501350**

Max Credits	Wghtd	FAS/FMS	IB	4 YR/GSV	CTE	SUS Admissn
0.50	N	N	E	C	N	N

Prerequisite(s): No Prerequisite, Prior level for Inter. & Adv.

Students will acquire basic knowledge and skills in weight training to assess, develop, and maintain their own muscular strength and endurance. They will study the importance of muscular strength and endurance, the skeletal structure and muscles, biomechanical and physiological principles, nutrition, and safety practices related to weight training. Cardiovascular fitness shall be emphasized in all weight training courses.

Gymnastics 1 (Intro to Circus)**Grades 9-10****1502300****Gymnastics 2 (Intro to Circus)****Grades 9-10****1502310**

Max Credits	Wghtd	FAS/FMS	IB	4 YR/GSV	CTE	SUS Admissn
1.00	N	N	N	C	N	N

Prerequisite(s): None

This course involves basic movement skills for body mechanics, self-testing skills, basic motor skills, perceptual and manipulative skills, and other movement activities for the improvement and maintenance of health and physical fitness. Students learn these new skills and techniques under The Big Top of The Sailor Circus. **Please note: Students who would like to apply for our Circus Magnet program after taking this course, may do so for the following school year.**

ACCESS Diploma Progression

(See page 15 for details)

Students eligible for an ACCESS diploma will take the following courses:

<i>English</i>	<i>Mathematics</i>	<i>Science</i>	<i>Social Studies</i>	<i>Others</i>
English 1	Algebra 1A	Earth Space	World History	HOPE
English 2	Algebra 1B	Integrated Science	US History	Self Determination
English 3	Geometry	Biology	Florida History	Career Prep/ Career Exp.
English 4	Financial Literacy		Government and Economics	Fine Arts Elective
				Team Sports/ PE
				Adult Living

Unique Skills

Grade 9-12

7963130

Max Credits	Wghtd	FAS/FMS	IB	4 YR/GSV	CTE	SUS Admissn
0.50	N	N	E	E	N	N

Prerequisite(s): For students with an IEP

The purpose of this course is to enable students with disabilities to acquire and generalize skills they need to achieve annual goals based on assessed needs and the student's individual educational plan (IEP). It is structured around the domains addressed on the IEP: Social and Emotional, Independent Functioning, Curriculum and Learning, and Communication.

DUAL ENROLLMENT OPTIONS

OFFERED THROUGH EMBRY-RIDDLE AERONAUTICAL UNIVERSITY ON SHS CAMPUS

INTRO TO ENGINEERING

Grade 12

EGR 101

SPATIAL REASONING

Grade 12

EGR 111/195A

Prerequisite(s): 3.00 GPA and Teacher Recommendation. **Please note: Additional requirements may be in place from university.**

This course is an introduction to the interdisciplinary aspects of the engineering of aerospace systems. It is a project-based course, demonstrating how the engineering profession is a multi-disciplinary field. Students are involved in an array of conceptual exercises, simple design activities, and projects dealing with engineering in aerospace-related areas.

UNIVERSITY OF SOUTH FLORIDA

For program details and requirements, please see your school counselor

UNIVERSITY OF FLORIDA ONLINE

For program details and requirements, please see your school counselor

STATE COLLEGE OF FLORIDA

For program details and requirements, please see your school counselor